

# Glowworm

## Installation & Servicing Instructions

To be left with the user

**FUELSAVER 35F** G.C Number 41 313 09

**FUELSAVER 45F** G.C Number 41 313 35

**FUELSAVER 55F** G.C Number 41 313 06

*F a n n e d F l u e B o i l e r s*

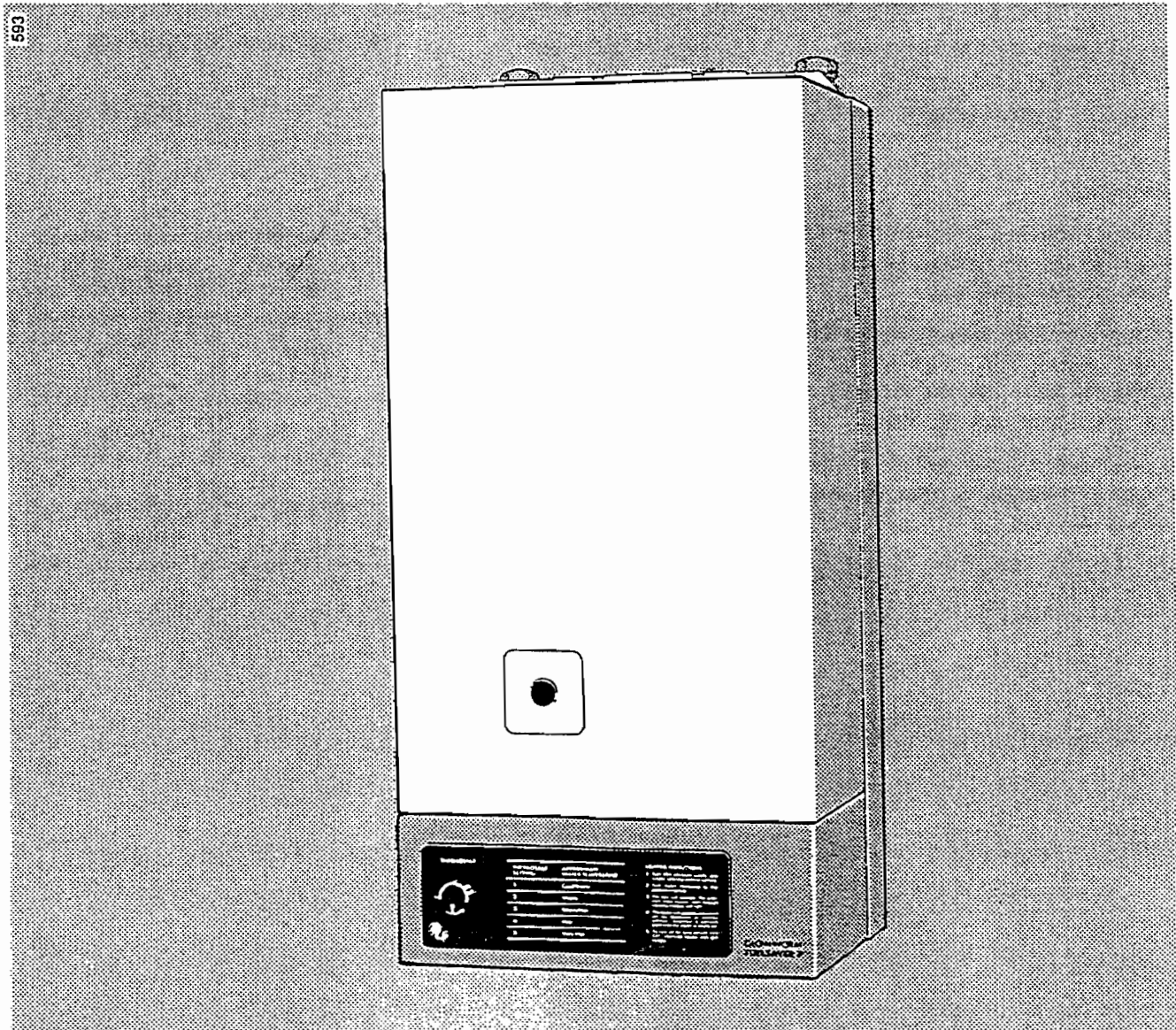

# 1 General

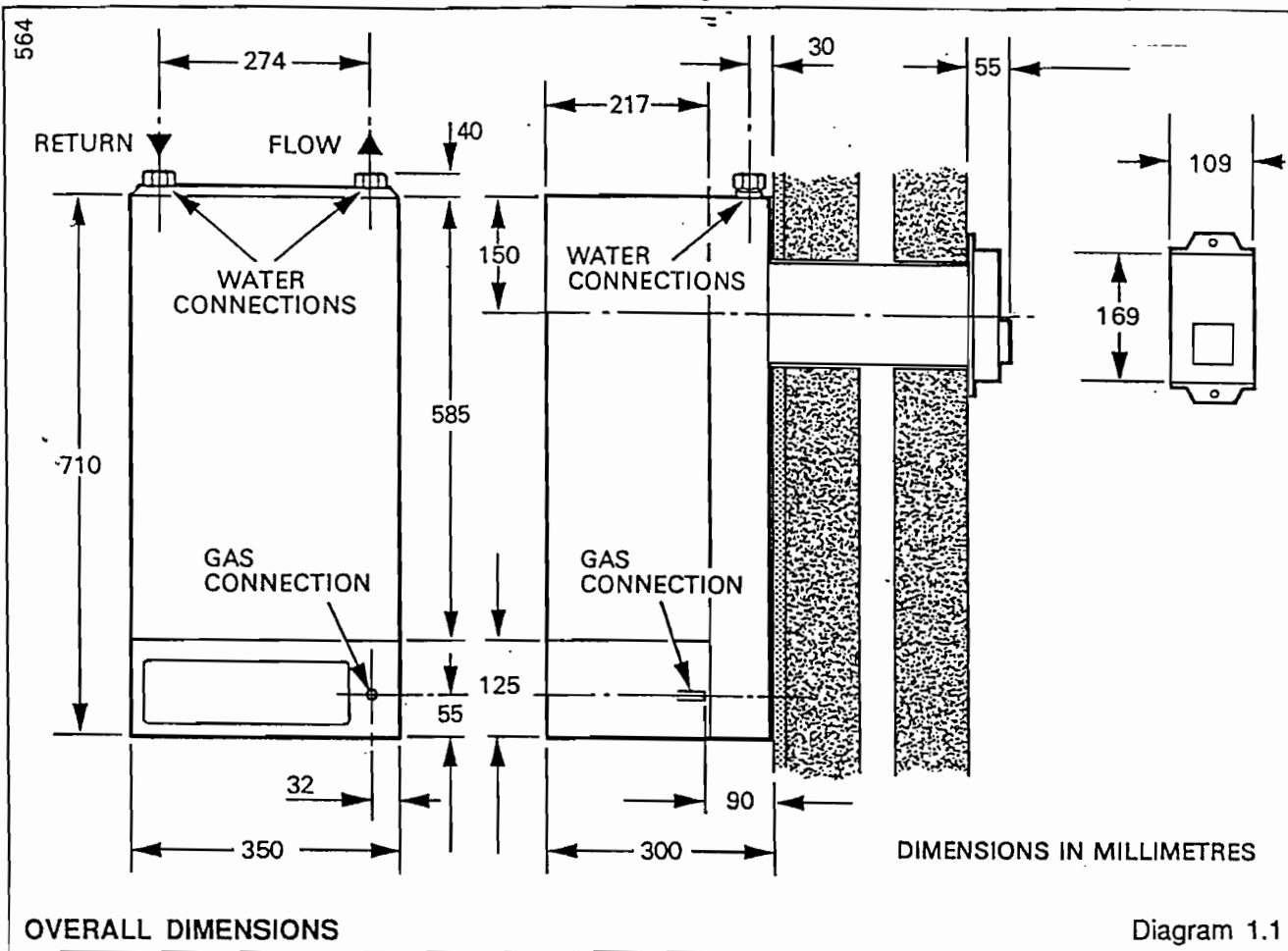

## 1 General

**Important Notice:** The Fuelsaver 35F, 45F and 55F are for use on natural gas only and must not be used on any other gas.

1.1 These are fully automatically controlled wall mounted, fanned flue, room sealed boilers, specially designed for fully pumped systems, giving ease of siting, installation and servicing.

The operation of these boilers is very simple with the user only having to turn the thermostat knob on or off as required.

MODEL	FUELSAVER 35F	FUELSAVER 45F & 55F
Weight of complete boiler	24 kg 53 lb	25 kg 55 lb
Water content	0.55 litre 1 pint	0.62 litre 1½ pint
Burner: Bray	AB 24030	AB 24031
Burner: Furigas	—	170.500.007

### 1.2 Range Rating

These boilers are range rated and may be adjusted to suit individual systems. The appropriate table gives settings and outputs.

The boiler input is factory preset at maximum rating and should be adjusted to suit the system requirements.

A self adhesive arrow indicator is supplied in the loose items pack for fixing on to the data badge, to indicate the adjusted setting.

### 1.3 Data

The data badge is positioned at the lower right of the boiler, above the model and serial number plate, visible when the white casing has been removed.

*Dimensions shown in diagrams are in millimetres.*

- Gas connection : Rc<sup>1</sup>/<sub>2</sub> (1/2 in BSP)
- Water connections : 22mm compression
- Electrical supply : 240V~50Hz fused at 3A

### 1.4 B.S.I. Certification

These boilers are certificated by BSI for safety and performance. It is, therefore, important that no alteration is made to the boilers unless recommended, in writing, by Hepworth Heating Ltd.

Any alteration that is not approved by Hepworth Heating Ltd., could invalidate the BSI certification, appliance warranty and could also infringe the statutory regulations.

### 1.5 Procedure

It is essential that the boiler is installed strictly in accordance with the instructions in this booklet.

### 1.6 Sheet Metal Parts

When installing or servicing this boiler, care should be taken when handling sheet metal parts, to avoid any possibility of personal injury.

FUELSAVER 35F				
RANGE RATING		min	medium	max
NOMINAL HEAT INPUT	<i>kW</i> <i>Btu/h</i>	7.44 25,400	- -	12.82 43,750
NOMINAL HEAT OUTPUT	<i>kW</i> <i>Btu/h</i>	5.86 20,000	8.79 30,000	10.26 35,000
BURNER SETTING PRESSURE	<i>m bar</i> <i>in.w.g</i>	5.5 2.2	10.0 4.0	13.0 5.2
BURNER INJECTOR MARKING: 2.85				

FUELSAVER 45F				
RANGE RATING		min	medium	max
NOMINAL HEAT INPUT	<i>kW</i> <i>Btu/h</i>	9.96 34,000	13.50 46,000	16.85 57,500
NOMINAL HEAT OUTPUT	<i>kW</i> <i>Btu/h</i>	7.33 25,000	10.26 35,000	13.19 45,000
BURNER SETTING PRESSURE	<i>m bar</i> <i>in.w.g</i>	5.1 2.0	8.8 3.5	13.2 5.3
BURNER INJECTOR MARKING: 3.4				

FUELSAVER 55F				
RANGE RATING		min	medium	max
NOMINAL HEAT INPUT	<i>kW</i> <i>Btu/h</i>	13.04 44,500	- -	20.15 68,750
NOMINAL HEAT OUTPUT	<i>kW</i> <i>Btu/h</i>	10.26 35,000	13.19 45,000	16.12 55,000
BURNER SETTING PRESSURE	<i>m bar</i> <i>in.w.g</i>	6.4 2.6	9.6 3.9	14.0 5.6
BURNER INJECTOR MARKING: 3.55				

## 1.7 Statutory Requirements

The installation of this boiler must be carried out by a competent person in accordance with the relevant requirements of the current issue of,

The Gas Safety (Installation and Use) Regulations, The Building Regulations, The Building Standards (Scotland) Regulations, applicable in Scotland, The I.E.E. Wiring Regulations, The Local Water Company Bye-laws.

Detailed recommendations are contained in the current issue of the following British Standard codes of practice,

BS6798, BS5440 Part 1 and 2, BS5446, BS6700, BS5449, BS6891, BS7074 Part 1 and 2.

## 1.8 Gas Supply

The gas installation must be fitted in accordance with the current issue of BS6891. The pipework from the meter to the boiler must be of adequate size, a smaller size than the boiler gas inlet connection must not be used.

The gas meter governor must ensure a constant outlet pressure of 20mbar (8in wg).

The size of the meter and pipework must take into account any other demand for gas.

Always test the complete gas installation for soundness and purge in accordance with the recommendations in the current issue of BS6891.

## 1.9 Electrical

The Boiler must be earthed.

The electrical installation must be carried out by a competent person.

All components shall be of the approved type and shall be connected in accordance with the current issue of The I.E.E. Wiring Regulations.

Connection of the boiler and any controls to the mains electrical supply must be through a 3A fused 3 pin plug and shuttered socket both to the current issue of BS1363. Alternatively, a 3A fused double pole isolating switch may be used, having a minimum double pole contact separation of 3mm, serving only the boiler and system controls.

Heat resistant cable to the current issue of The I.E.E. Regulations must be used to connect up the boiler and controls.

### 1.10 Boiler Location

The boilers are not suitable for installation out of doors.

The boiler position should be such that the minimum clearances are provided as shown in diagram 1.2. Additional clearances may be required around the boiler for installation. Sufficient clearance must be left in front of the boiler for servicing.

The boiler may be installed in any room, although particular attention is drawn to the requirements of the current issue of The I.E.E. Wiring Regulations for electrical installations with respect to the installation of the boiler in a room containing a bath or shower. Any electrical switch or boiler control using mains electricity should be so situated that it cannot be touched by a person using the bath or shower. The electrical provisions of the Building Standards (Scotland) Regulations are applicable to such installations in Scotland.

Where the installation of the boiler will be in an unusual location, special procedures are necessary and the current issue of BS6798 gives detailed guidance.

A compartment used to enclose the boiler must be designed and constructed specifically for this purpose. An existing cupboard or compartment may be used providing that it is modified for the purpose, see Section 2.5. Details of essential features of cupboard and compartment design are given in the current issue of BS6798.

The boiler must be mounted on a flat noncombustible surfaced wall which is sufficiently robust to take its weight.

Combustible materials on the wall surface must be protected by a noncombustible sheet, at least the size of the boiler, not less than 25mm thick.

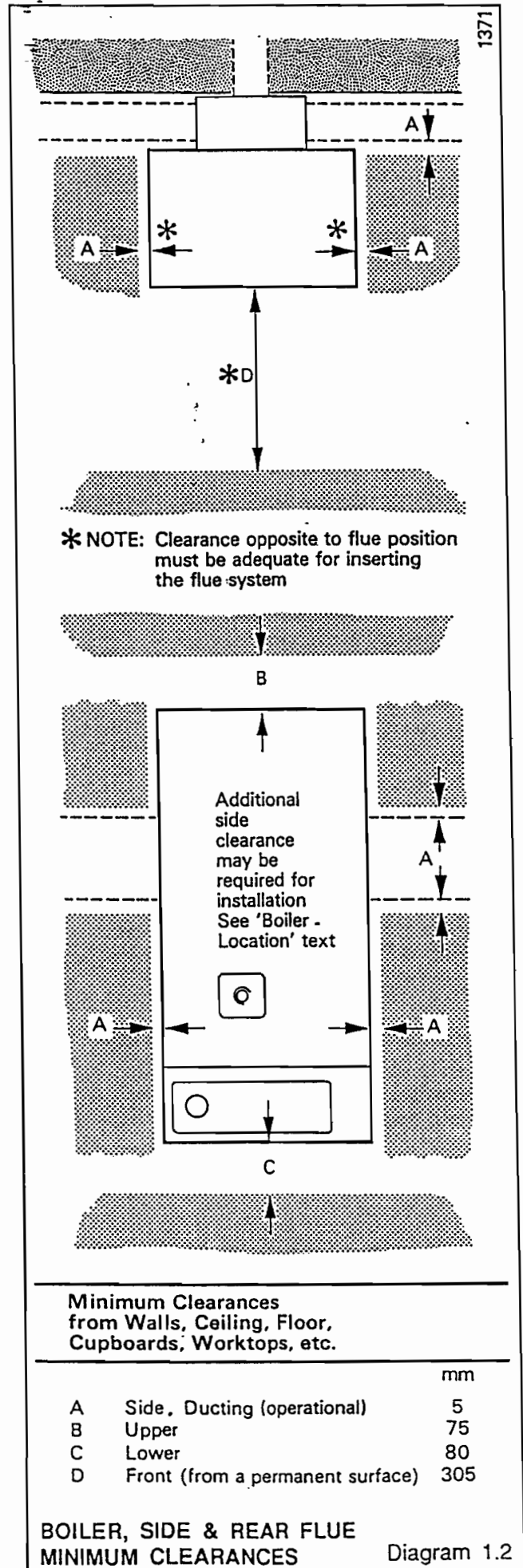

## 2 Flue and Ventilation

### 2.1 Flue

Detailed recommendations for flues are given in the current issue of BS5440 Part 1.

The boiler must be installed so that the terminal is exposed to the external air. It is important that the position of the terminal allows the free passage of air across it all times, see diagram 2.1.

**Flue Systems.** Various types of flue systems are available where access to the outside wall is possible, to suit various installation requirements, see diagrams A1, B1 and C1.

**Internal Access Kits.** Where access to the outside terminal position is not practical, additional kits of parts are available to enable the flue and terminal to be installed from the inside of the building, see diagrams D1, E1 and F1.

**Note:** The boiler is supplied with the standard flue pack, any additional flue kit(s) will need to be ordered, quoting the part number.

The minimum spacings from the terminal to obstructions, other terminals and ventilation openings are specified in diagram 2.1.

Car ports or similar extensions of a roof only, or a roof and one wall, require special consideration with respect to any openings, doors, vents or windows, under the roof. Care is required to protect the roof if made from plastic sheeting. Seek further advice if the car port comprises of a roof and two or more walls, from the local gas undertaking.

If the terminal is fitted within 850mm of a plastic or painted gutter or 450mm of painted eaves, an aluminium shield at least 750mm long should be fitted on the underside of the gutter or painted surface.

The air inlet/products outlet duct and the terminal of the boiler must not be closer than 25mm to combustible material. Refer also to the current issue of BS5440 Part 1.

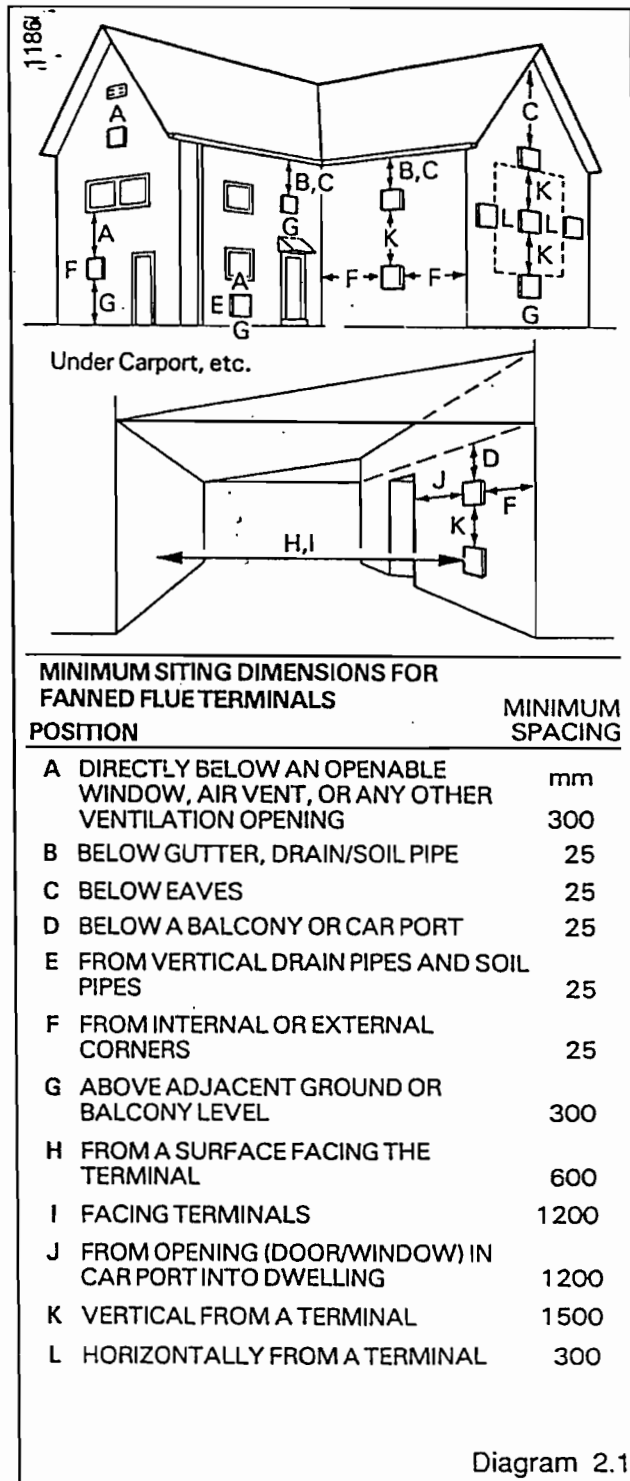
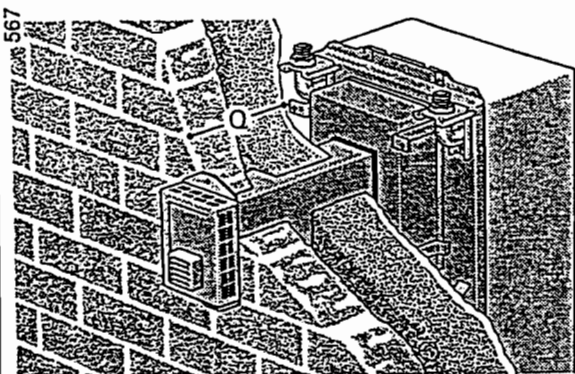

Diagram 2.1



## Type A. REAR FLUE - STANDARD or LONG



PACK No.                      DISTANCE 'Q'.  
 Standard Pack-417210      75 to 580mm (3 to 22<sup>3</sup>/<sub>4</sub> in)  
 Long Kit                      578 to 1970mm  
 417233+417210              (22<sup>3</sup>/<sub>4</sub> to 77<sup>1</sup>/<sub>2</sub> in) Diagram A1

## Type D. REAR FLUE - with INTERNAL ACCESS INSTALLATION KIT

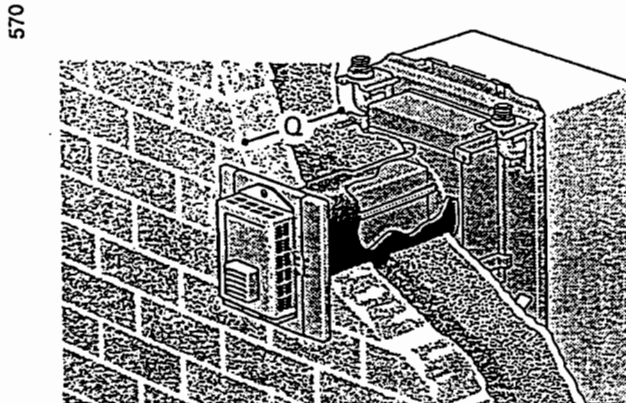

PACK No. 417210 + KIT No.417240  
 DISTANCE 'Q': 70 to 580mm (2<sup>3</sup>/<sub>4</sub> to 22<sup>3</sup>/<sub>4</sub> in)  
 Diagram D1

## Type B. SIDE FLUE - STANDARD Left or Right

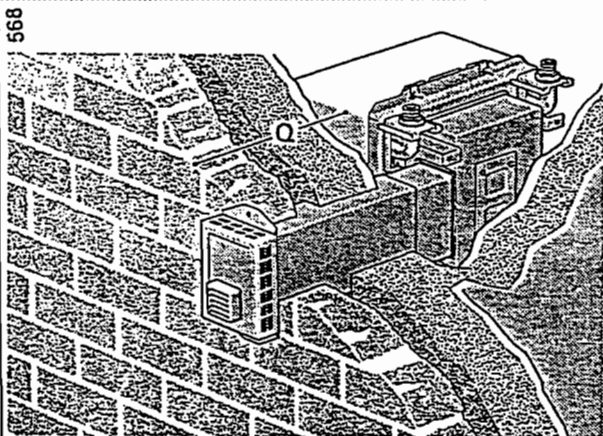

PACK No. 417210 - Standard  
 DISTANCE 'Q': 80 to 496mm (3<sup>1</sup>/<sub>4</sub> to 19<sup>1</sup>/<sub>2</sub> in)  
 Diagram B1

## Type E. SIDE FLUE - STANDARD Left or Right with INTERNAL ACCESS INSTALLATION KIT

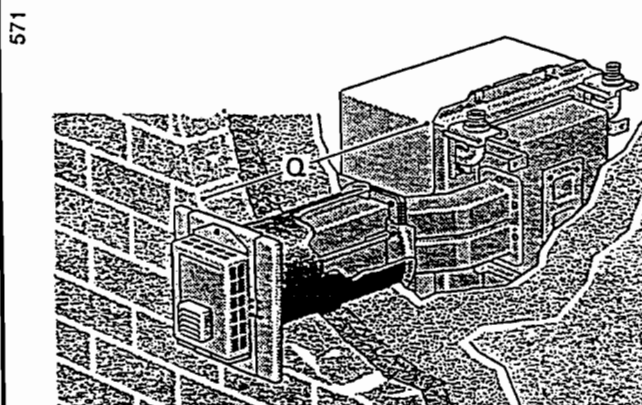

PACK No. 417210 + KIT No.417240 +  
 ADAPTOR KIT No. 417256  
 DISTANCE 'Q': 204 to 625mm (8 to 24<sup>5</sup>/<sub>8</sub> in)  
 WALL THICKNESS: 75 to 492mm (3 to 19<sup>3</sup>/<sub>8</sub> in) Diagram E1

## Type C. SIDE FLUE - LONG Left or Right

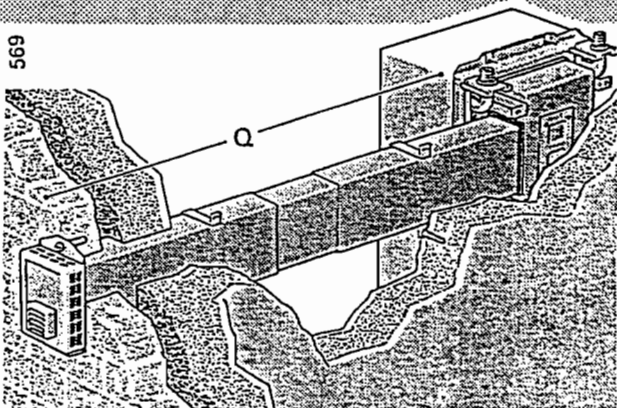

KIT No. 417233 - Long + Standard Pack No. 417210  
 DISTANCE 'Q': 496 to 1887mm (19<sup>1</sup>/<sub>2</sub> to 74<sup>1</sup>/<sub>4</sub> in)  
 Diagram C1

## Type F. SIDE FLUE - LONG Left or Right with INTERNAL ACCESS INSTALLATION KIT

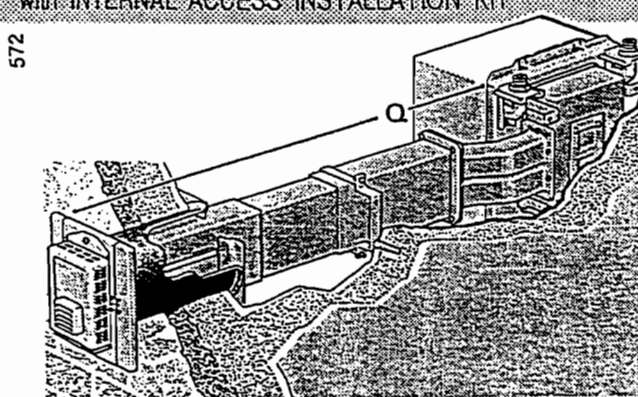

PACK No. 417210 + KIT No.417240 + KIT No. 417233  
 + ADAPTOR KIT No. 417256  
 DISTANCE 'Q': 625 to 2016mm (24<sup>5</sup>/<sub>8</sub> to 79<sup>3</sup>/<sub>8</sub> in)  
 WALL THICKNESS: 75 to 492mm (3 to 19<sup>3</sup>/<sub>8</sub> in) Diagram F1

## 2 Flue and Ventilation

### 2.2 Timber Frame Buildings

If the appliance is to be installed in a timber frame building it should be fitted in accordance with the British Gas Publication "Guide for Gas Installation in Timber Framed Housing" reference DM2. If in doubt, seek advice from the local gas undertaking, or Hepworth Heating Ltd.

### 2.3 Terminal Protection

A terminal guard is required if persons could come into contact with the terminal or the terminal could be subject to damage.

If a terminal guard is required, it must be positioned to provide a minimum of 50mm clearance from any part of the terminal and be central over the terminal.

Guards are available from Tower Flue Components Ltd., telephone Tonbridge 351555, quoting reference "H" or from Quinnell, Barrett and Quinnell Ltd., 884, Old Kent Road, London, SE15, quoting reference "C52".

### 2.4 Room Ventilation

Where the boiler is fitted in a room or space, no permanent air vent is required.

### 2.5 Cupboard/Compartment Ventilation

Where the boiler is fitted in a cupboard or compartment, the ventilation area must be in accordance with the Air Vent Table.

Note: Both the high and low level air vents must communicate with the same room or internal space, or must both be on the same wall to outside air.

FUELSAVER 35F				
COMPARTMENT AIR VENT TABLE				
POSITIONS OF AIR VENTS	AIR VENT AREAS			
	AIR FROM ROOM OR INTERNAL SPACE		AIR DIRECT FROM OUTSIDE	
HIGH VENT	115cm <sup>2</sup>	18in <sup>2</sup>	58cm <sup>2</sup>	9in <sup>2</sup>
LOW VENT	115cm <sup>2</sup>	18in <sup>2</sup>	58cm <sup>2</sup>	9in <sup>2</sup>

FUELSAVER 45F				
COMPARTMENT AIR VENT TABLE				
POSITIONS OF AIR VENTS	AIR VENT AREAS			
	AIR FROM ROOM OR INTERNAL SPACE		AIR DIRECT FROM OUTSIDE	
HIGH VENT	152cm <sup>2</sup>	24in <sup>2</sup>	76cm <sup>2</sup>	12in <sup>2</sup>
LOW VENT	152cm <sup>2</sup>	24in <sup>2</sup>	76cm <sup>2</sup>	12in <sup>2</sup>

FUELSAVER 55F				
COMPARTMENT AIR VENT TABLE				
POSITIONS OF AIR VENTS	AIR VENT AREAS			
	AIR FROM ROOM OR INTERNAL SPACE		AIR DIRECT FROM OUTSIDE	
HIGH VENT	181cm <sup>2</sup>	28in <sup>2</sup>	91cm <sup>2</sup>	14in <sup>2</sup>
LOW VENT	181cm <sup>2</sup>	28in <sup>2</sup>	91cm <sup>2</sup>	14in <sup>2</sup>



### 3.1 Pump

The pump should be fitted in the flow from the boiler. It is recommended that a pump producing at least 2.5 metres (8ft) head is used, to give a flow rate through the boiler of:

- Fuelsaver 35F: 13.3litre/min 2.9gal/min
- Fuelsaver 45F: 17.2litre/min 3.8gal/min
- Fuelsaver 55F: 21litre/min 4.6gal/min

This will give a temperature difference of about 11°C (20°F).

For details of pressure loss, see diagram 3.1 or 3.2.

High resistance microbore systems may require a higher duty pump.

Use a pump with integral valves or fit valves as close to the pump as possible.

### 3.2 Cylinder

The hot water cylinder must be of the double feed type. Single feed (self priming type) are not recommended and must not be used on a sealed system.

### 3.3 Safety Valve

The provision of a safety valve is not necessary for an open vented system, but if a safety valve is fitted it must be fitted in accordance with the current British Standard 6798.

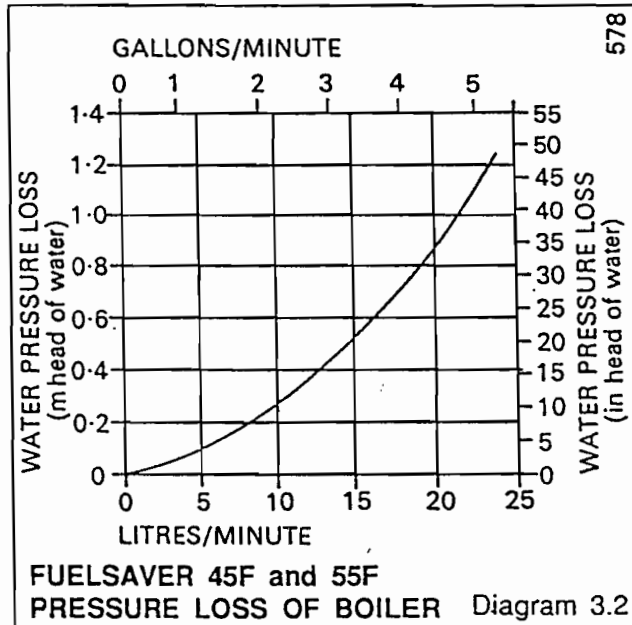
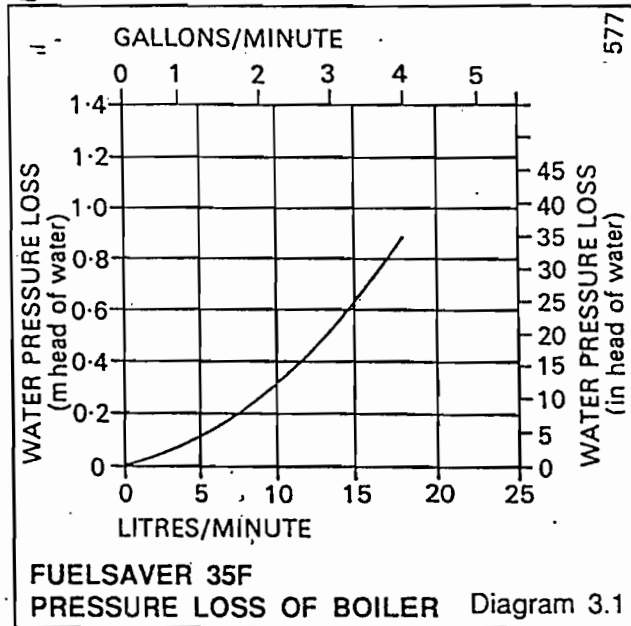

## 3 Water System

### 3.4 By Pass

It is essential to fit a by pass on all installations. A suggested convenient position is shown in diagram 3.3.

### 3.5 Open, Vented, Water System

A 22mm outside diameter open vent must be fitted in the flow from the boiler and terminated above the cold feed and expansion cistern, which should be not less than 22litres (5gallons) capacity, see diagram 3.3.

The vent must have a continuous rise to discharge over the cistern. Horizontal runs should be avoided. There must be no intervening valve or cock.

The cistern must not be situated more than 27.5metre (90ft) above the boiler.

A 15mm outside diameter minimum cold feed must be fitted in the system.

For an open, vented, water system it is important that the relative positions of the pump, cold feed and open vent should be as shown in diagram 3.3.

### 3.6 Controls

Any remote boiler switch control must be connected to replace the red link between terminals 7 and 12SL on the boiler.

The pump must be connected directly to the boiler control box in accordance with diagram 7.3.

Any remote system controls should be installed in accordance with the appropriate manufacturer's instructions.

### 3.7 Draining

A drain tap must be provided at the lowest points of the system which will allow the drainage of the entire system and hot water cylinder.

Drain taps shall be to the current issue of BS2979.

A drain point is provided on the boiler for heat exchanger draining.

### 3.8 Water Connections

The boiler has compression connections, with olives and nuts supplied loose, to accept 22mm outside diameter copper tube to BS2871.

The right hand connection is the flow from the boiler.

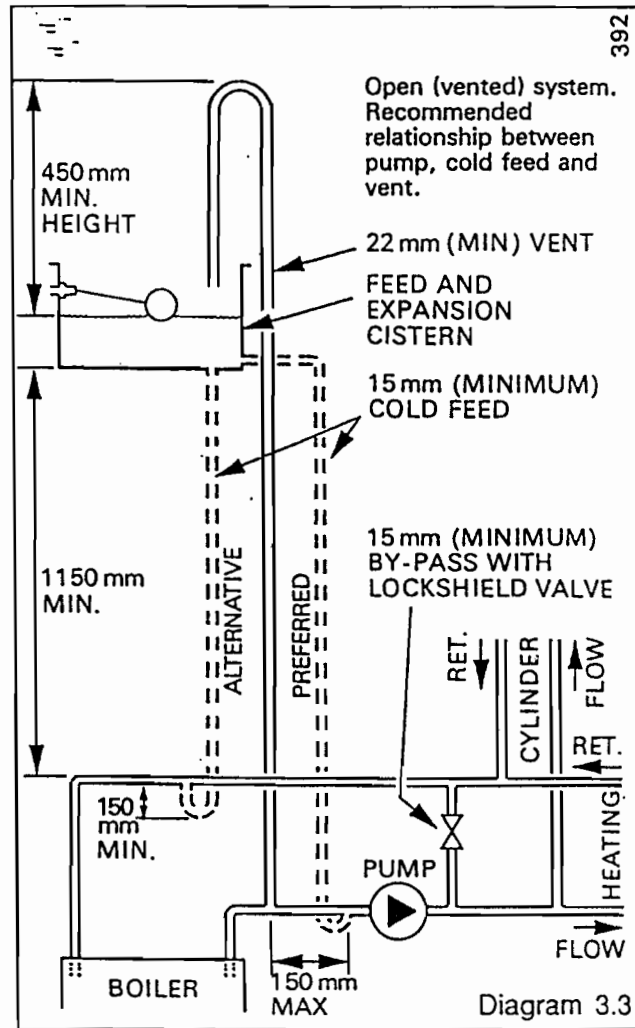

### 3.9 Inhibitor

Attention is drawn to the current issue of BS5449 on the use of inhibitors in central heating systems.

If an inhibitor is to be used, contact a manufacturer for their recommendations as to the best product to use.

When using in an existing system take special care to drain the entire system, including the radiators, then thoroughly flushing out before fitting the boiler and adding the inhibitor.

4.1 General Requirements

The installation should comply with the current issue of BS5449, BS6798 and BS7074 Part 1 and 2. See diagram 4.1 for a suggested layout.

4.2 Safety Valve

A safety valve must be fitted to a sealed system. The safety valve must be fitted in accordance with the requirements of the current issue of BS6798. It shall be preset, non-adjustable with a lift pressure of 3bar, incorporating seating of a resilient material, a test device and a connection for drain.

4.3 Expansion Vessel

A diaphragm type expansion vessel conforming to the current issue of BS4814 (see also BS7074 Part 1 and 2) must be connected at a point close to the inlet side of the circulating pump, see the diagrammatic layout, unless laid down differently by the manufacturer.

The expansion vessel volume depends on the total water system volume and the initial system design pressure. For any system an accurate calculation of vessel size is given in the current issue of BS7074 Part 1.

Example: For an initial system design pressure of 0.7 bar, the minimum total vessel volume required is  $0.063 \times \text{Total system volume}$ .

Note: A higher initial design pressure requires a larger volume expansion vessel.

Guidance on vessel sizing is also given in the current issue of BS5449.

The charge pressure must not be less than the static head of the system, that is, the height of the highest point of the system above the expansion vessel.

The water capacity of the boiler is given in the Data Table.

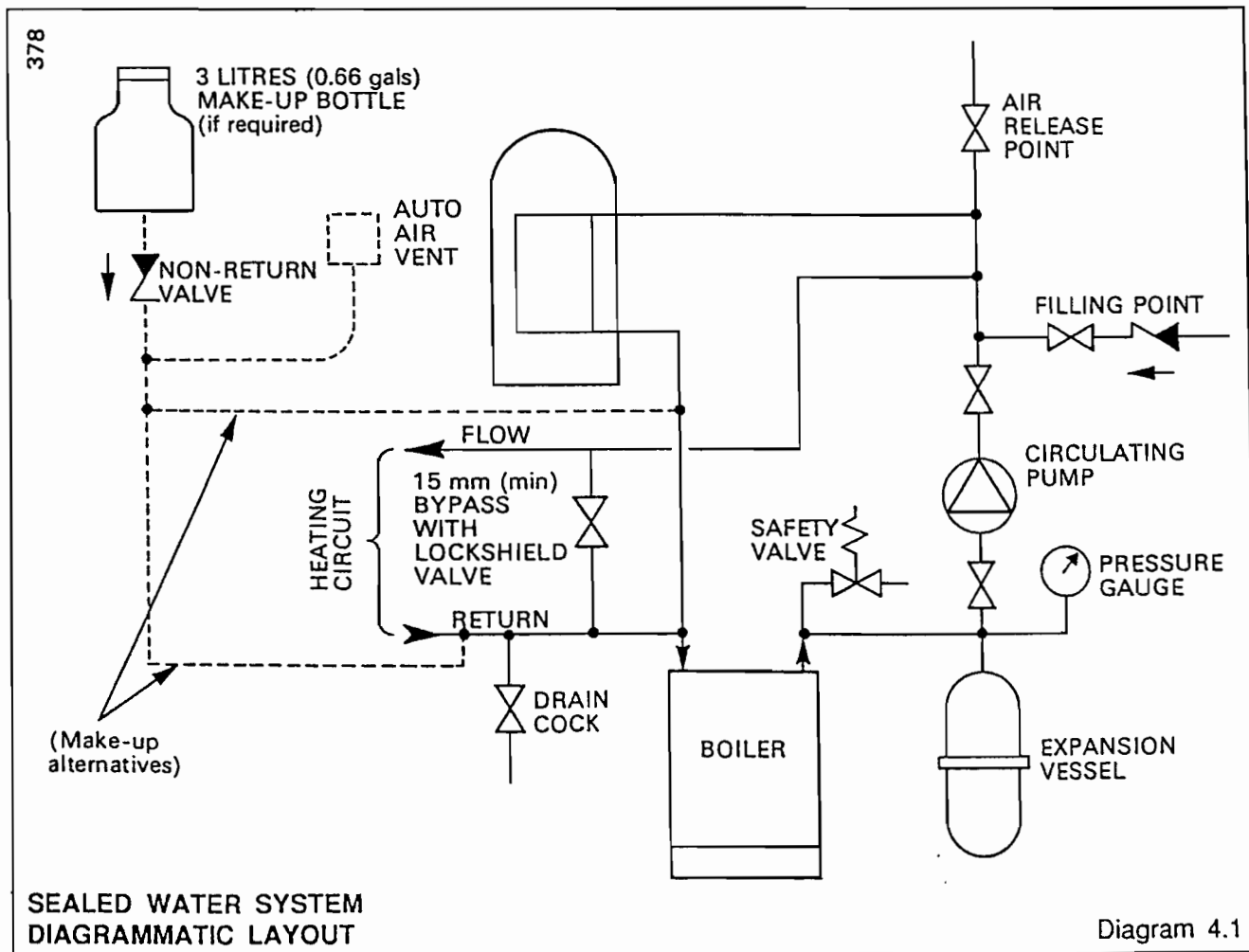

SEALED WATER SYSTEM DIAGRAMMATIC LAYOUT

Diagram 4.1

#### 4.4 Pressure Gauge

A pressure gauge with a set pointer and covering at least 0 to 4 bar (0 to 60lb/in<sup>2</sup>) shall be fitted permanently in a position where it can be seen when filling the system.

#### 4.5 Domestic Hot Water Cylinder

SINGLE FEED INDIRECT CYLINDERS ARE NOT SUITABLE.

The hot water cylinder must either be of the indirect coil type or a direct cylinder fitted with an immersion heater calorifier. It must be suitable for working at a gauge pressure of 0.35bar above the safety valve setting.

#### 4.6 Water Make Up

Provision should be made for replacing water loss from the system using a make up bottle or filling loop mounted in a position higher than the top point of the system, connected through a non-return valves to the return side of either the heating circuit or the hot water cylinder.

Alternatively, provision for make up can be made by pre-pressurisation of the circuit.

#### 4.7 Filling Sealed Systems

Provision for filling the system at low level must be made. Three methods are shown in diagram 4.2. There must no permanent connection to the mains water supply, even through a non-return valve.

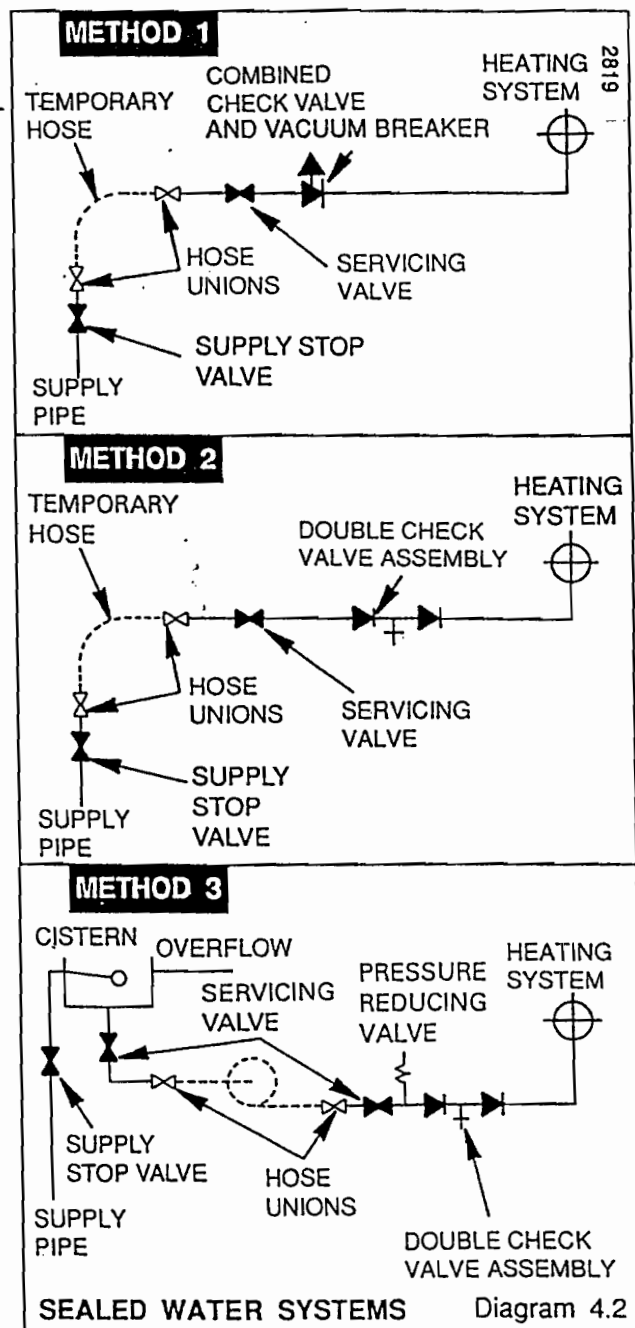

### 5.1 Unpacking

Remove wall template and cardboard fitting from the boiler carton and remove the rear side panels, which are packed within this fitting.

Slide the controls cover forward to remove from the boiler.

Remove the boiler from the carton and place on its back.

The loose items pack will be found in the carton.

### 5.2 Flue Box

Remove the casing after unscrewing the two upper and two lower securing screws, see diagram 5.1.

Remove the flue box from behind the back panel of the boiler by removing the four screws, see diagram 5.2.

The flue box is used with the flue components to mount on the wall as described in the appropriate flue instructions, which are supplied in the flue pack and kits.

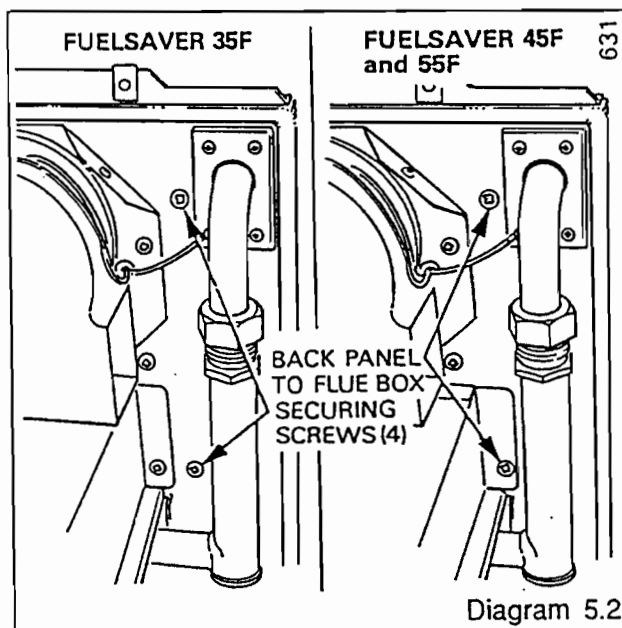
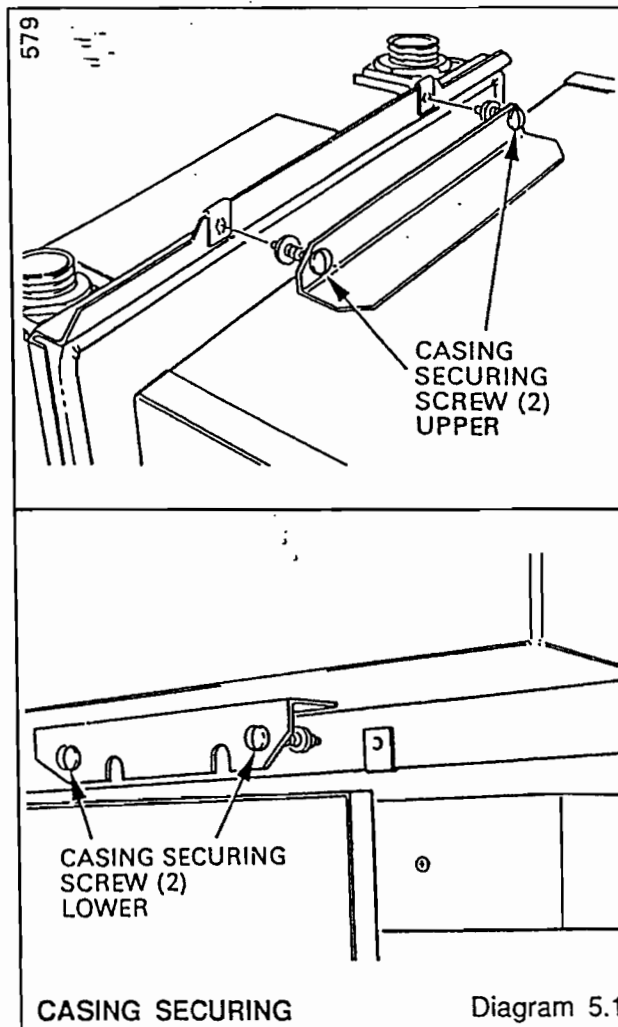

## 6 Boiler Fixing

### 6.1 Flue System

Refer to instructions supplied with the flue pack to be used, ensuring that the flue is correct for the installation, including any internal access flue kit, if applicable.

The flue box, lower support bracket and flue system must now be fitted to enable the boiler to be installed, refer to the appropriate flue instructions.

### 6.2 Mounting the Boiler

Proceed as follows, after installing the flue system required.

Take one or both rear side panels, if required, then hook on at the top and secure with the No6 self tapping screws provided.

In the case of a side flue installation the rear side panel on the flue side will require the knock-out panel removing after the larger flange has been cut, see diagram 6.1.

Position the boiler centrally on the lower support bracket previously fixed on the wall and ease the boiler back to the flue box, securing with the four screws previously removed, see diagram 5.2.

### 6.3 Gas Connection

Make the connection to the gas supply at the union gas service cock at the base of the boiler.

Test the complete gas installation for soundness and purge in accordance with the current issue of BS6891.

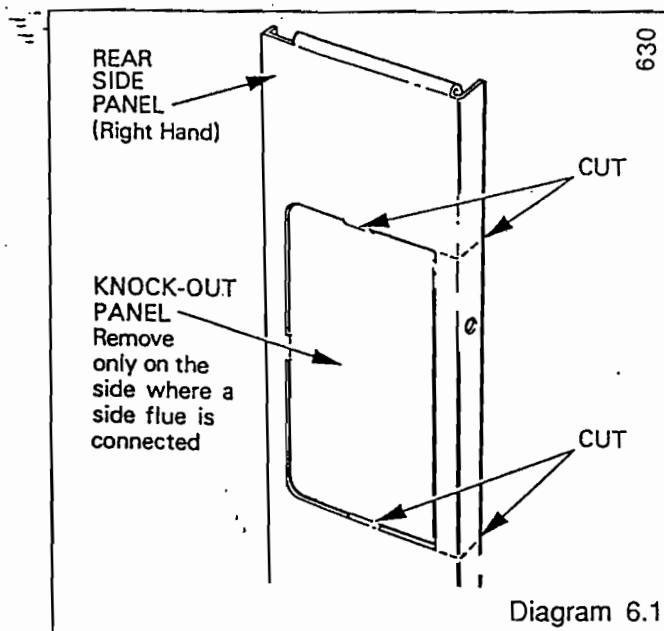

## 7 Electrical

**This boiler must be earthed and have a permanent mains supply.**

The electrical installation must comply with the current issue of The I.E.E. Wiring Regulations.

All cables connected to the boiler control box or controls must conform to the requirement of the current issue of the I.E.E. Wiring Regulations.

### 7.1 Supply Cable Connection

Remove the control box by supporting it and removing the two fixing screws at the front above the fascia, then lower the front of the box until it is clear of its cover. Push the box to the rear to disengage its hinging arrangement, lower the box and pull forward clear of its cover, see diagram 7.1.

The box will still be attached to the boiler by the retaining strap. If the box is to be removed entirely, pull the strap off the plastic fastener. Care should now be taken not to damage thermostat and overheat cutoff capillaries or any electrical cables.

Using heat resistant cable of suitable length and rating as stated in Section 1.9, thread the mains cable through a hole in the rear of the control box, through the cable clamp and connect to the appropriate terminals and earth stud, see diagram 7.2 and 7.3.

When making connections, ensure that the earth conductor is made of a greater length, so that if the cable is strained the earth conductor would be the last to be disconnected.



For installations with less than 150mm lower clearance, allow an extra 300mm of installation cables to permit servicing of the control box. Make a loop in the cable and secure with a cable clip at the rear.

It is essential that the polarity is correct, the live, connected to 11 and the neutral connected to 10, see diagram 7.3.

The electrical isolator must isolate both the boiler and any system controls, be adjacent to the boiler and clearly marked showing its purpose, refer to Section.1.9.

### 7.2 Pump Cable Connection

The pump must be connected directly to the boiler control box as shown in diagram 7.3, passing the cable through the hole in the rear of the control box.

### 7.3 Testing

Checks to ensure electrical safety must be carried out by a competent person.

In the event of an electrical fault after installation of the appliance, preliminary system checks must be carried out as described in a multimeter instruction book.

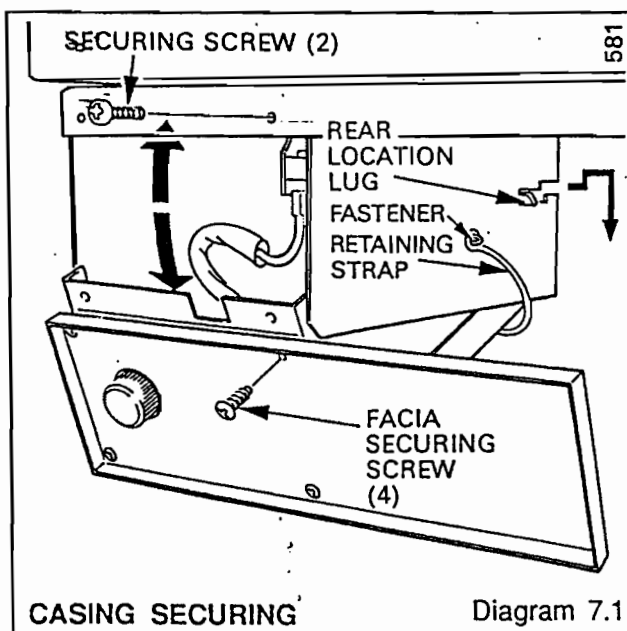

CASING SECURING

Diagram 7.1

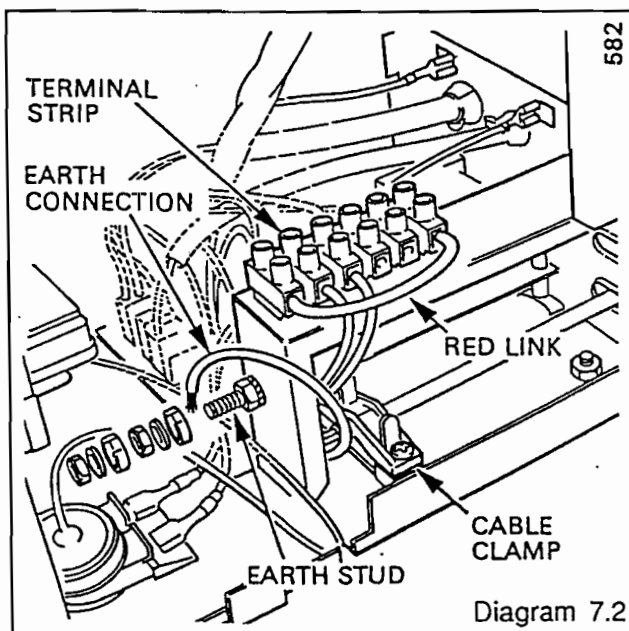

Diagram 7.2

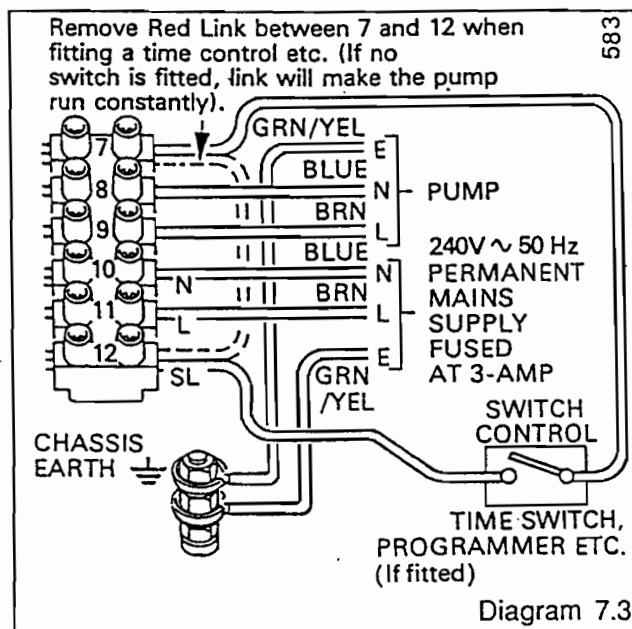

Diagram 7.3

## 8 Commissioning

### 8.1 Preliminaries

The system must be thoroughly flushed out with cold water without the pump in position.

Refit the pump and fill the system, making sure that all the air is vented from the system and pump.

### 8.2 Sealed System

Flush the whole system with cold water without the pump in place. Refit the pump and fill until the pressure gauge registers 1.5bar (21.5lb/in<sup>2</sup>). Clear any airlocks and check for water leakage.

Check the operation of the safety valve, preferably by allowing the water pressure to rise until the valve lifts. This should be within  $\pm 0.3$ bar ( $\pm 4.4$ lb/in<sup>2</sup>), of the preset pressure. Where this is not possible carry out a manual check.

Release the cold water to initial design pressure.

### 8.3 Initial Lighting, Testing and Adjustment

Check that the main electrical supply to the boiler is switched off and that the boiler thermostat is set to "O", see diagram 8.1.

Turn on the main gas supply as the gas service cock.

Test for soundness around the pilot connection as follows: Remove the cover from the gas valve, see diagram 8.1. Temporarily disconnect the black cable from the gas valve solenoid and insulate the connector with insulation tape. Switch on the electrical supply to the system.

**Warning.** The gas valve and fan operate on Mains voltage, terminals will become "LIVE".

Turn thermostat knob fully clockwise and the fan will start, sparks should be generated and the pilot ignite. If the pilot burner will not ignite, press the reset button under the control box, see diagram 8.1. If the pilot will still not ignite, temporarily attach rubber tubing over the open end of the air pressure tube and position the open end of the rubber tubing adjacent to the fan outlet, see diagram 8.2. Sparks will then be generated and the pilot ignite. Check around the pilot connections for gas soundness with a suitable leak detection fluid.

Turn the thermostat knob "O" and isolate the boiler from the electrical supply.

Replace the black cable and remove the rubber tubing.

Position the self adhesive arrow indicator on to the data badge against the output to which the boiler is going to be set to, the arrow is in the loose items pack.

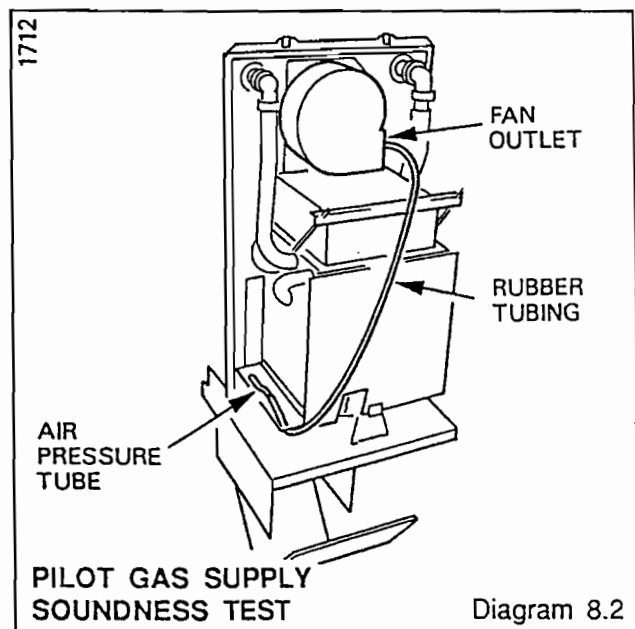
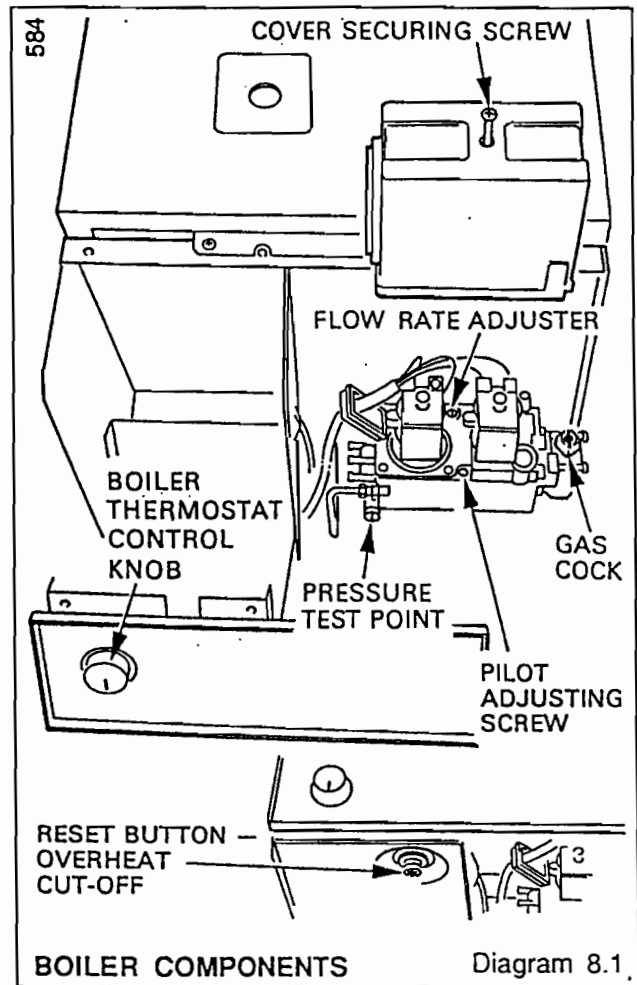

Fit the outer casing making sure that it is correctly fitted, sealed and secured with the two upper and two lower screws previously removed.

The boiler will not work without the casing being fitted.

**Note:** Before lighting the boiler ensure that the casing has been correctly fitted and that the edge of the cover makes a tight seal with the sealing strip on the groove around the boiler backplate.

Remove the cap screw and fit a suitable gauge to the pressure test point, see diagram 8.1.

**Warning:** The gas valve operates on mains voltage and the terminals will become "live".

Ensure that all remote controls are calling for heat.

Switch on the mains electrical supply to the system and check that the pump is working.

Turn the boiler thermostat knob clockwise to a high setting and after a period of time the main burner will light, check through viewing window.

If the boiler does not light, press the reset button under the control box, see diagram 8.1.

Should the boiler still not light then check all electrical connections and refer to the fault finding section.

The pilot gas rate is preset fully open on the gas valve and no adjustment should be necessary. Check that the flame lengths are as in diagram 8.3. If any adjustment is required, turn pilot adjusting screw, clockwise to decrease, see diagram 8.1.

Set the gas rate required by means of the flow rate adjusting screw, see diagram 8.1, turning clockwise to decrease. Beware of mains voltage on the terminals. Refer to pressure settings for heat output appropriate in the Range Rating Table 1.

Turn thermostat knob to "O" and isolate the boiler from the electrical supply. Remove the pressure gauge and refit the test point screw.

Replace the gas valve cover and secure with the screw.

Relight boiler and check that there is adequate air for combustion, by the correct appearance of the flames.

Should any doubt exist about the gas rate check it at the meter 10 minutes after lighting up. The gas rate should be in the range of:

Fuelsaver 35F : 0.7 to 1.2m<sup>3</sup>/h 25 to 44ft<sup>3</sup>/h

Fuelsaver 45F : 1 to 1.6m<sup>3</sup>/h 34 to 58ft<sup>3</sup>/h

Fuelsaver 55F : 1.3 to 1.9m<sup>3</sup>/h 45 to 69ft<sup>3</sup>/h

These rates are approximate for guide purposes, depending on the heat setting.

Test for gas soundness around the test point and the boiler components at the base, using a suitable leak detection fluid.

The boiler will give off a "burning" smell for a period of time after initial lighting.

Replace the control box, engage the rear location lugs on side of box on to bottom edge of cover and slide box backward. When the box is at the rear of the cover raise rear of box to engage pivot arrangement and raise front of box then replace the two screws previously removed, see diagram 8.4. Refit the retaining strap on to the fastener if the control box has been removed completely.

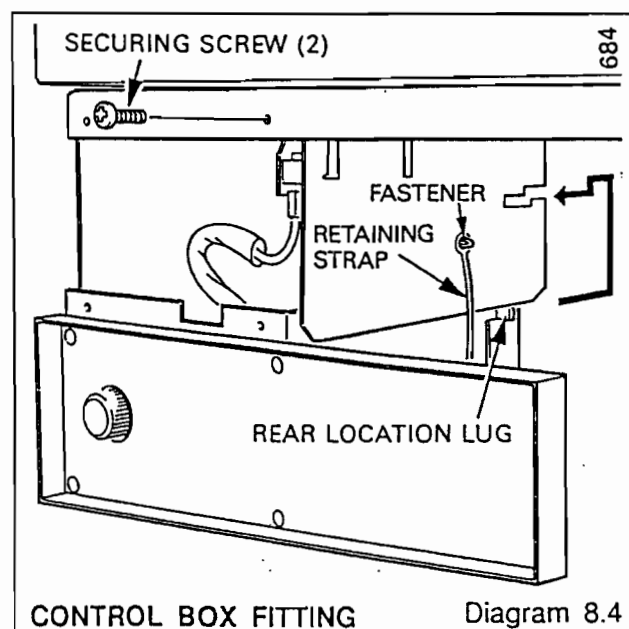
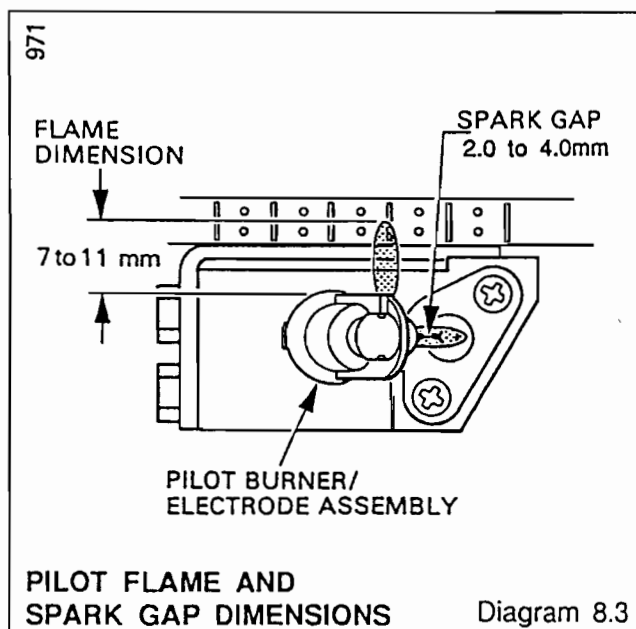

### 8.4 System

Check that all remote controls are calling for heat.

For sealed systems refer also to Section 4.

Allow the system to reach maximum working temperature and examine for leaks. The boiler should then be turned off and the system drained as rapidly as possible whilst still hot.

Refill the system, vent all air and check for water leakage.

Sealed systems should be adjusted to the initial system design pressure. Any set pointer on the pressure gauge should be set to coincide with the indicating pointer.

The overrun thermostat will keep the pump running when the boiler has shut down, as long as the water temperature within the boiler is above a predetermined limit.

When commissioning the system the boiler should first be fired with the bypass valve fully closed on full service, that is, central heating and domestic hot water. The system should then be balanced, adjusting the pump and lockshield valve as necessary. Having achieved a satisfactory condition, operate the boiler with the bypass fully closed on minimum load, normally this will be central heating only, with one radiator operating in the main living area. The valve should be gradually opened to achieve the appropriate flow rate as quoted in Section 3.1. If necessary readjust the pump.

Under no circumstances must this valve be left in the fully closed position.

### 8.5 Operational Checks

Adjust the boiler thermostat and any system controls to the required setting.

Operate the boiler again on full service and check the balancing is satisfactory, making further adjustments as necessary.

If thermostatic radiator valves are fitted, care must be taken to ensure that there is an adequate flow rate when the valves close.

Check that there is no pumping over of water or ingress of air at the open vent above the feed and expansion cistern.

### 8.6 Normal Lighting Sequence

THE BOILER MUST NOT BE OPERATED WITHOUT THE CASING BEING CORRECTLY FITTED, SEALED AND SECURED TO THE BACK PANEL.

Turn on the electrical and gas supplies.

Check that all remote controls are calling for heat.

Turn the boiler thermostat clockwise to the setting required, giving the following automatic lighting sequence.

- a) The fan will run
- b) The air pressure switch operates
- c) The first, pilot solenoid valve opens
- d) The spark igniter operates
- e) Pilot burner will ignite
- f) Ignition spark switches off
- g) The second solenoid opens giving main burner operation until the boiler thermostat or remote system control switch the boiler off.

When the boiler switches off, all burners are off, the lighting sequence operates when heat is required again.

If the boiler thermostat is turned off, by hand, wait 30 seconds before turning on again.

### 8.7 Completion and User Information

Refit the controls cover by sliding on to the runners.

Instruct the user in the operation of the boiler and system.

Hand the User Instructions to the user for their retention.

Advise that, to ensure the continued efficient and safe operation of the boiler it is recommended that it is checked and serviced as necessary at regular intervals. The frequency of servicing will depend upon the particular installation conditions and usage, but in general once a year, preferably at the end of the heating season, should be enough.

It is the law that any servicing must be carried out by a competent person.

Leave these Installation Instructions with the user for use during future service calls.

It is the law that any servicing must be carried out by a competent person.

Before commencing a service, turn off the gas supply at the gas service cock and isolate the electrical supply.

After completing any servicing or replacement of gas carrying parts, always test for gas soundness and carry out functional check of controls.

## 9.1 Heat Exchanger Cleaning

Remove controls cover by pulling it forward and clear of the appliance.

Unscrew the two upper and two lower casing securing screws and remove the outer case by withdrawing forward, see diagram 9.1.

Remove the wing nuts and the flue hood securing angle, see diagram 9.2.

Remove the two screws securing the flue hood to the backplate and lift off the hood, taking care not to damage the gasket at the back.

Remove the combustion chambers front panel by removing the wing nut at the bottom and the four screws securing it to the combustion chamber sides.

Disconnect the ignition lead from the electrode, taking care not to damage the lead insulation.

Support the main burner and unscrew the tubing nut at the base of the pilot burner.

Spring the pilot tube downward sufficiently to allow the main burner to move forward to disengage from the injector at the rear. Raise the burner up through the combustion chamber and remove. Take care not to damage the insulation inside the combustion chamber.

Protect the pilot tube and injector.

Place a sheet of paper in the bottom of the combustion chamber and brush any deposits from the heat exchanger

Remove the paper any any deposits.

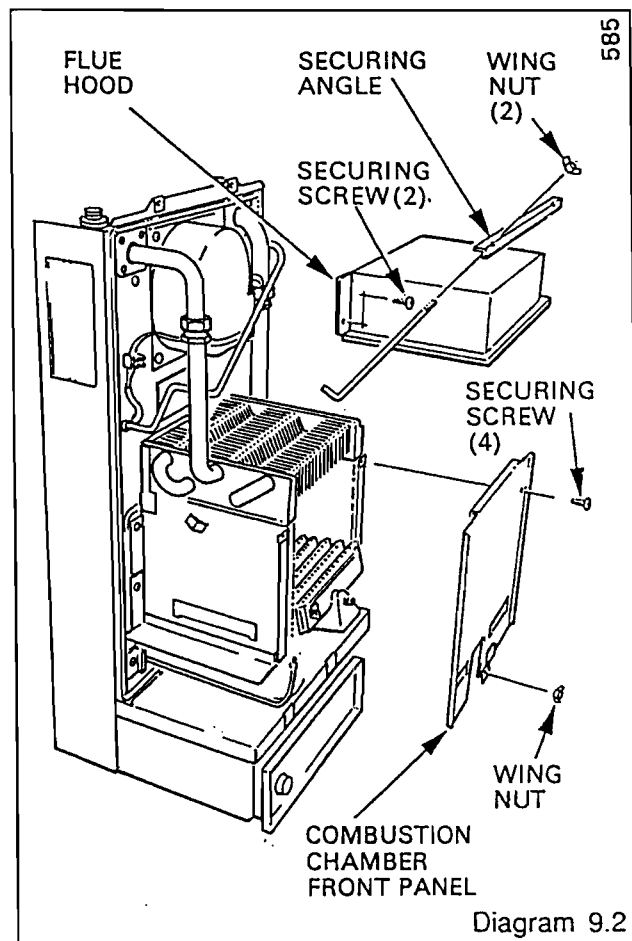
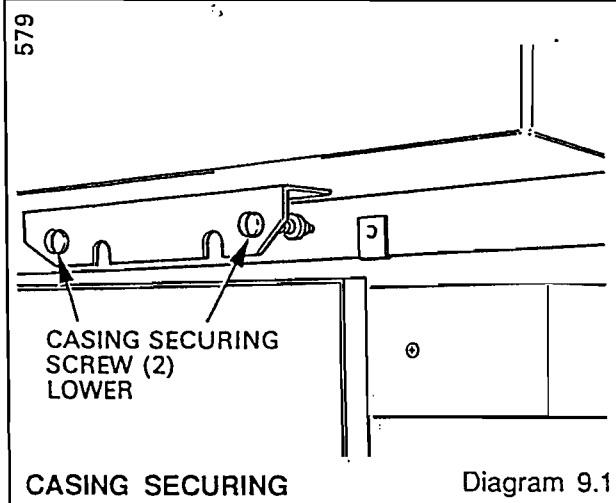
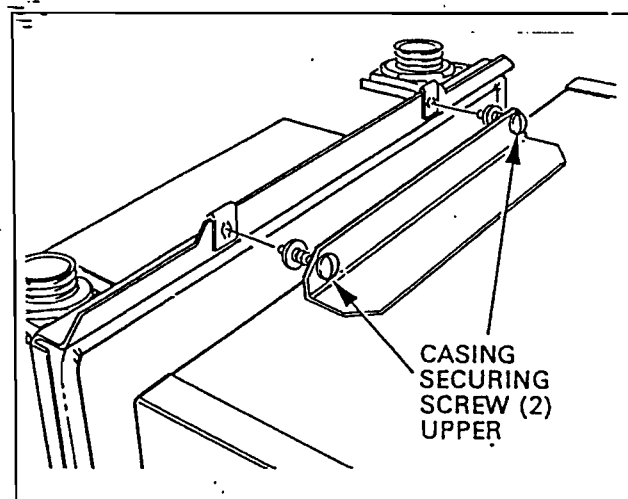

### 9.2 Burner Injector and Pilot Cleaning

With the main burner already removed, brush off any deposits from the burner, ensuring that the flame ports are unobstructed.

Do not use a brush with metallic bristles.

Check the main burner injector for blockage or damage and remove if necessary. When replacing, make sure that the sealing washer is in position to ensure a gas tight seal.

Inspect the pilot burner and ignition electrode, clean if necessary. Check condition of components.

Replace parts in reverse order.

Make sure that the main injector is pushed fully home on to the injector and between the vertical guides near the injector.

When replacing the flue hood make sure that a good seal is made to the back panel by replacing two screws at the rear then the two hook bolts, angle and wing nuts at the front. Do not over tighten the wing nuts.

### 9.3 Operational Checks

After completion of the service, before fitting the case, check the casing seal to ensure it is in good condition and renew it if necessary.

The boiler will not work without the casing being correctly fitted, sealed and secured to the back panel. Before turning the boiler on after completing the service, make that this is checked.

Light the boiler and carry out the operational checks as described in Section 8.3.



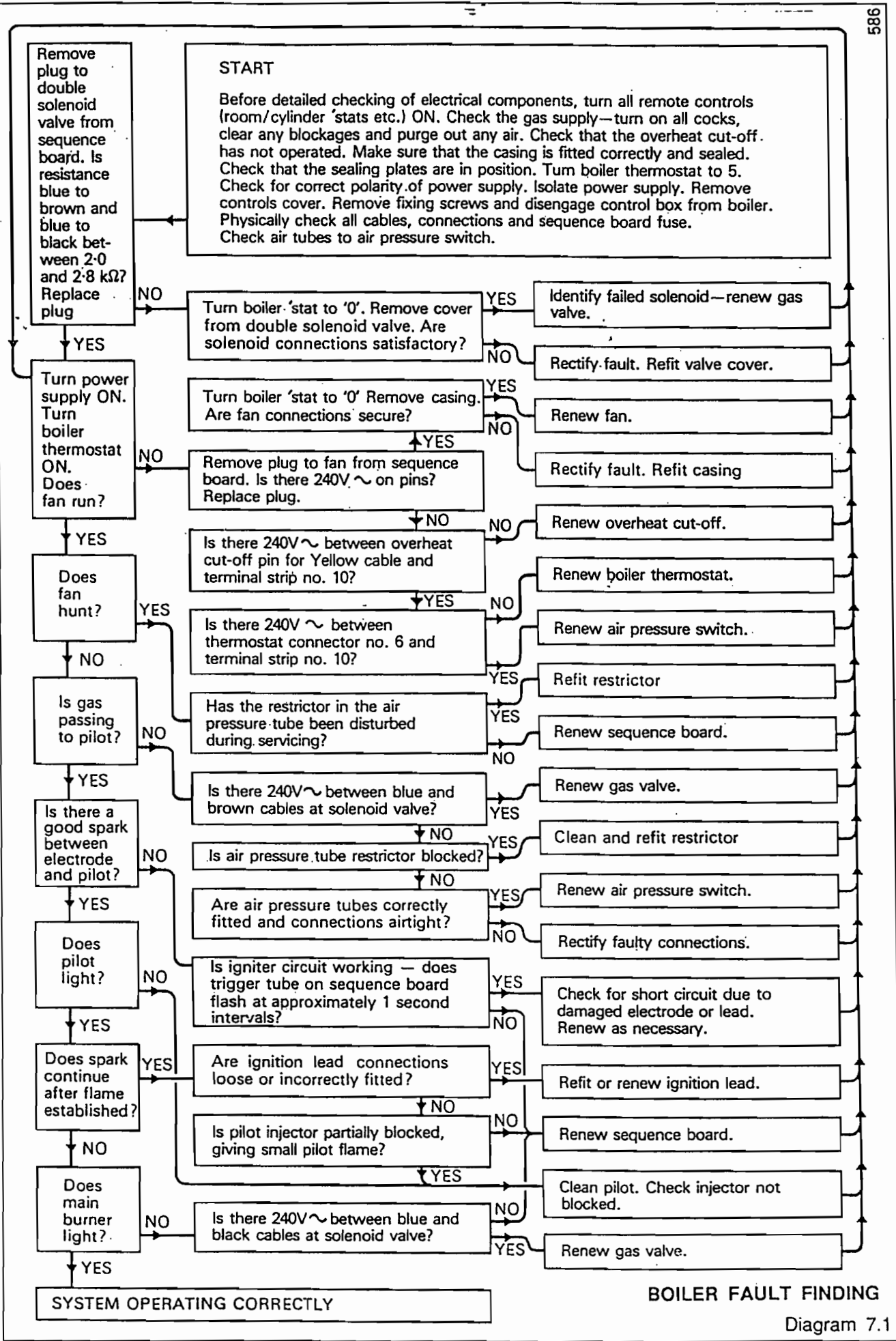

BOILER FAULT FINDING

Diagram 7.1

# 10 Fault Finding

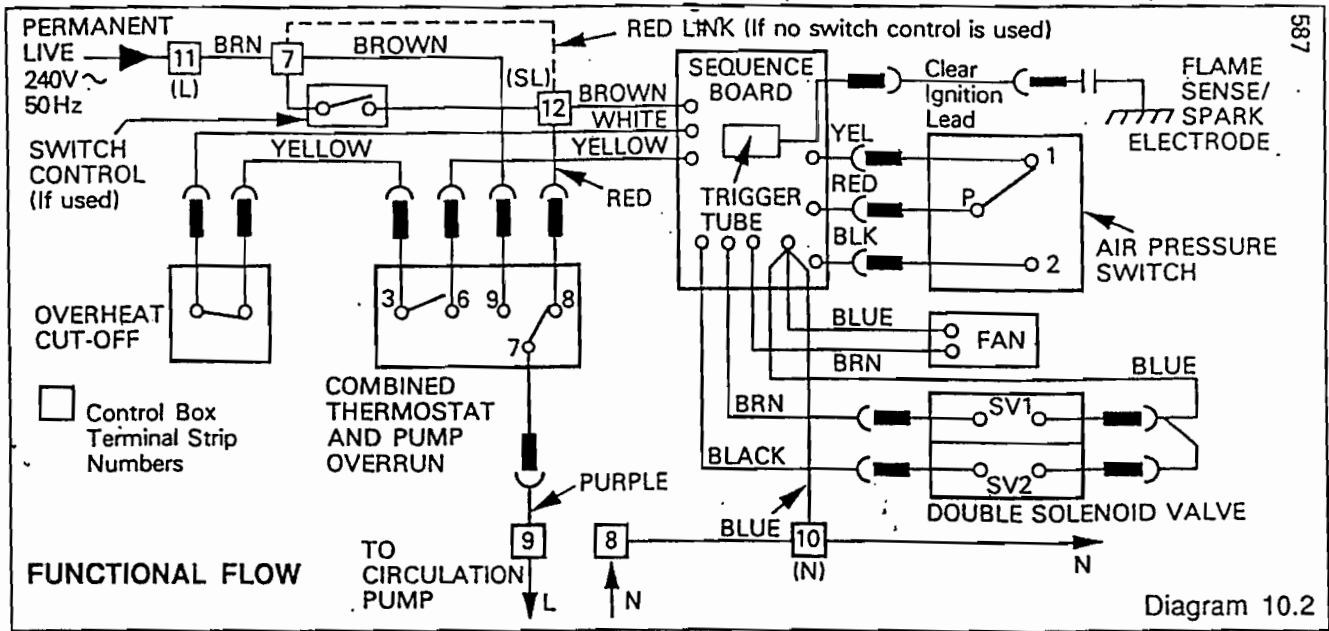

## 10.1 Electrical

**Important.** The preliminary electrical system checks contained in a multimeter instruction book are the first checks to be carried out during a fault finding procedure. On completion of the service/fault finding task which has required the breaking and remaking of electrical connections then the checks, earth continuity, polarity and resistance to earth must be repeated.

Refer to fault finding diagram 10.1 and functional flow wiring diagram 10.1.

A spare fuse for the sequence board is supplied in the front of the control box.

The boiler will not work unless the outer casing is correctly fitted, sealed and secured to the back panel.

<b>Cause</b>	<b>Remedy</b>
<b>10.2 Burner will not light</b>	
Electrical fault _____	Refer to 10.1 'Electrical Fault Finding'.
Boiler thermostat not working. _____	Check that boiler thermostat is in an "ON" position and working correctly.
Overheat cutoff operated. _____	Allow system to cool and press reset button, see diagram 8.1.
Case Seal Fault. _____	Make sure that the case is fitted correctly and sealed. Check that sealing plates are in position.
<b>10.3 Thermostat Will Not Cut Out</b>	
Thermostat phial not correctly fitted. _____	Fit phial in pocket, using heat sink compound and secure with retaining clip.
Faulty thermostat. _____	Replace.
<b>10.4 Overheat Device Cuts Out Prematurely</b>	
Air in heating body. _____	Vent system. Alter system layout if necessary.
Water circulation low or stopped. _____	Pump not working correctly. Check that pump is connected to the boiler, to work while boiler is on. Alter layout if necessary.
Overheat cutoff works before boiler cycles on maximum boiler thermostat setting. _____	Change faulty overheat cutoff.
Correctly set overheat cutoff works prematurely. _____ (First two items above are satisfactory).	Change faulty heating body.
<b>10.5 Not Enough Heat</b>	
Thermostat set too low. _____	Increase setting. Check for correct operation.
Gas supply pressure inadequate. _____	Check gas supply, clear any blockages, make sure all cocks are fully open.
Burner pressure incorrect (While measuring pressure ensure thermostat is on maximum setting). _____	Check burner pressure against data badge. Reset only if more than 10% away from required figure.
<b>10.6 Boiler Noisy Whilst Working*</b>	
Over gassed. _____	Check burner pressure against data badge and adjust if necessary, but only if more than 10% away from required figures.
Complete lack of water flow. _____	Check system controls for correct installation or correct type of controls.
Air in system. _____	Remove air from system. When boiler first commissioned the air dissolved may take some time to boil out, therefore, attempts should be made regularly during the first weeks of use to remove the air. Check venting of the system as air bubbles can remain suspended in the water if system is not well vented.
Water flow rate. _____	Check that flow rate is correct. Check that pump is of correct size and is correctly adjusted. By-pass not fitted or set correctly.

\* There remains on most boilers a residual noise which is more noticeable at high temperatures. Normal operation of the boiler over a period should remove most noise.

## 11 Replacement of Parts

### 11.1 Notes:

Replacement of parts must be carried out by a competent person.

Unless stated otherwise all parts are replaced in the reverse order to removal.

Before removing any parts turn off the gas supply at the service cock and isolate the electrical supply.

After replacement of any gas carrying part always test for gas soundness with a suitable leak detection fluid.

The boiler will not work without the casing being correctly fitted, sealed and secured to the back panel. Before turning the boiler on again make sure that this is checked.

Carry out functional checks of controls after replacing any parts.

### 11.2 Burner Injector

Remove the main burner as in Section 9.1

The injector, at the rear of the combustion chamber, can be unscrewed and replaced as necessary. Renew the sealing washer to ensure gas soundness.

When replacing the main burner ensure that it is pushed fully home on the injector and between the vertical guides near the injector.

### 11.3 Gas Valve

Remove the controls cover by sliding it forward. Make sure that the gas and electrical supplies are off.

Remove the four screws and fascia from the control box, see diagram 11.1.

Remove the cover to the gas valve by removing the screw, see diagram 11.2.

Disconnect the electrical connectors at the gas valve.

Disconnect the pilot supply tube nut at the gas valve, ease tube from pilot adaptor and transfer adaptor to the replacement valve.

Support the gas valve, remove the four screws from the flanged connections at each end of the valve and remove valve by easing the flanges apart.

Ensure that the new "O" rings are in place in the flanged connections when replacing.

The gas pipe may have to be purged of air after this operation. Test for gas soundness with a suitable leak detection fluid.

Refer to diagram 11.3 when connecting the electrical connectors.

Follow the instructions in Section 8.3.

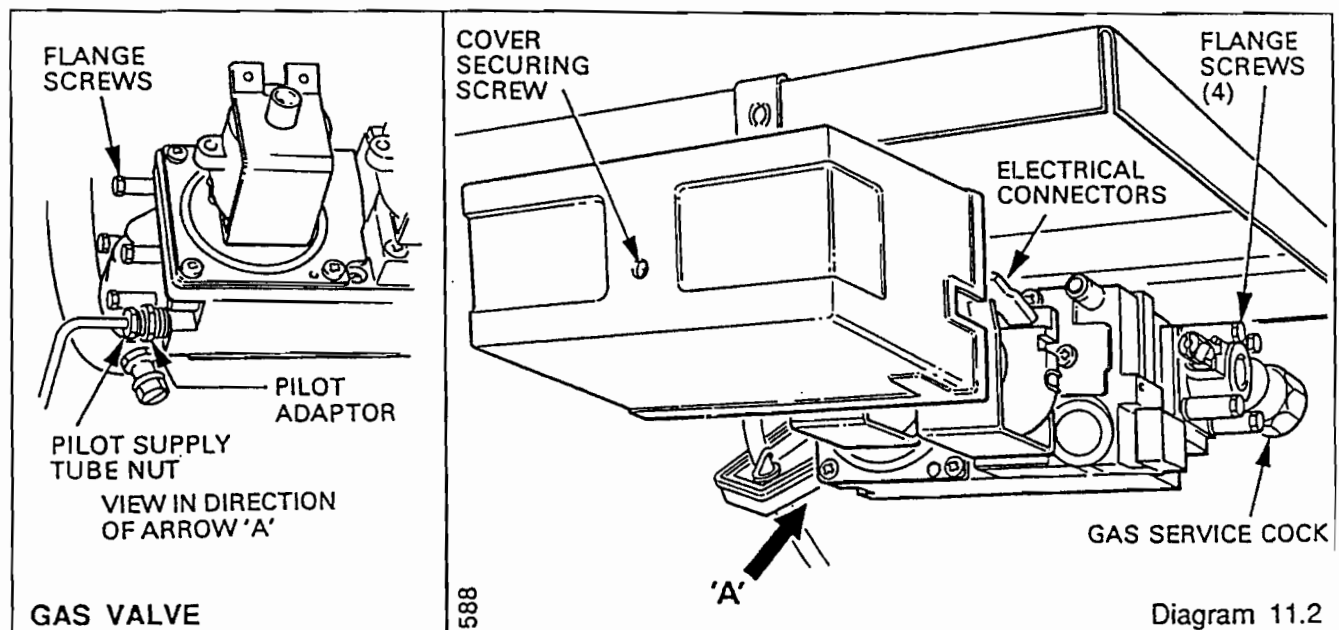
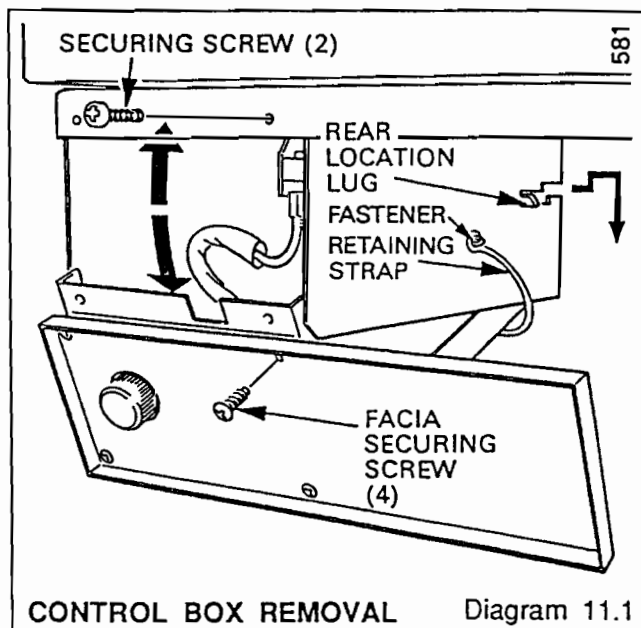

589

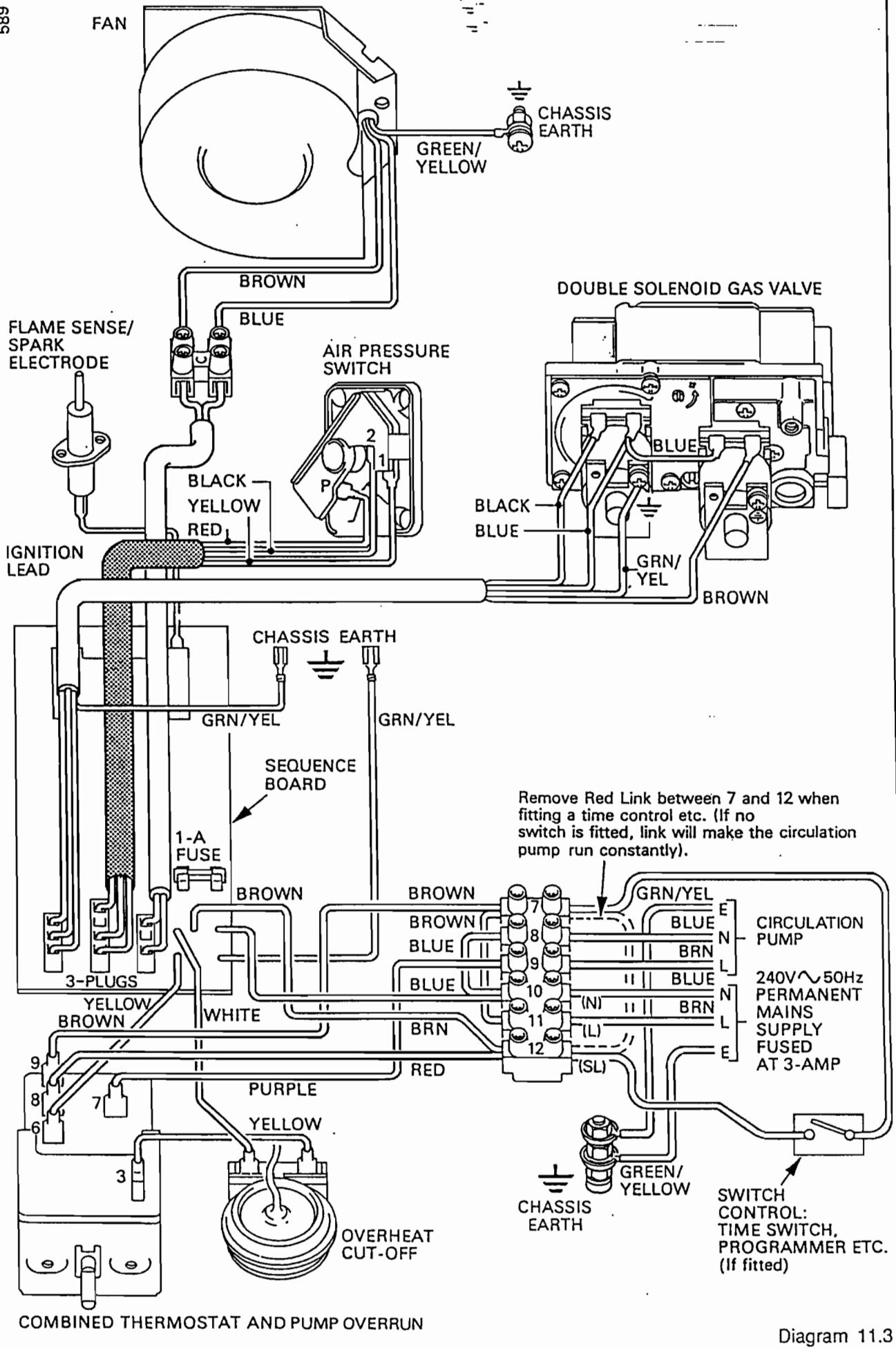

Diagram 11.3

## 11 Replacement of Parts

### 11.4 Air Pressure Switch

Ensure that the electrical supply is isolated.

Remove the controls cover by sliding it forward, turn off gas cock.

Remove the control box by supporting it and removing the two securing screws at the front above the fascia, then lower the front of the box until it is clear of its cover. Push box to the rear to disengage its hinging arrangement, lower rear of box and pull forward clear of its cover, see diagram 11.1. The box will still be attached to the appliance by the plastic retaining strap. If the box is to be removed entirely, pull the strap off the plastic fastener. Care should now be taken not to damage thermostat and over heat cutoff capillaries or any electrical cables.

Disconnect the electrical connectors at the air pressure switch, see diagram 11.4.

Push air pressure switch upward against spring plate and pull bottom to the left to disengage from its clip.

Disconnect the flexible tubes at the rear of the switch, taking care not to lose the air restrictor in the lower connection.

When replacing the tubes to the air pressure switch, note that the air restrictor must be fitted into the lower connection marked  $\ominus$ . Make sure that the flexible tubes are not kinked when replacing the switch.

See diagram 11.3 when reconnecting the electrical connectors.

Replace the control box; engage rear location lugs on side of box on to bottom edge of cover and slide box backward. When box is at rear of cover, raise rear of box to engage pivot arrangement and raise front of box then replace the two screws previously removed, see diagram 11.5. Refit the retaining strap on to the fastener if the control box has been removed completely.

### 11.5 Air Restrictor

Isolate electrical supply and release or remove the control box as in Section 11.4.

Remove the air pressure switch and lower flexible tube as in Section 11.4, see diagram 11.4.

Remove the air restrictor, marked "A" from the lower air pressure switch connection. Renew it or clean by blowing out and obstruction. Fit into lower connection marked  $\ominus$ .

When replacing air restrictor and pressure switch, ensure that the flexible tubes are not kinked.

Refit the control box as Section 11.4.

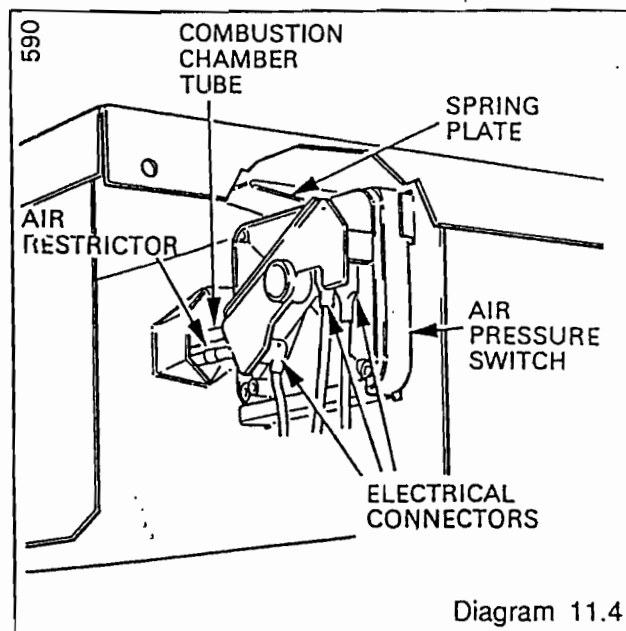
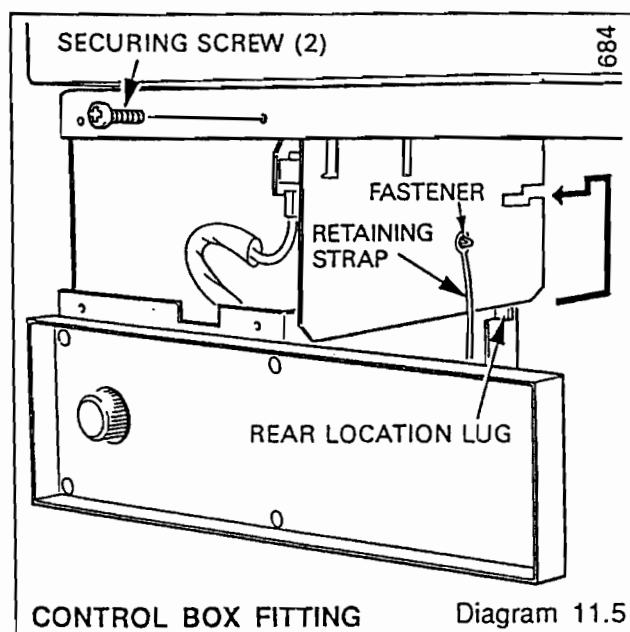

Diagram 11.4



CONTROL BOX FITTING

Diagram 11.5



### 11.6 Sequence Board

Ensure that the electrical supply is isolated.  
 Remove the controls cover by sliding it forward.  
 Release or remove control box as Section 11.4.  
 Disconnect the three multi pole plugs at the front of the board and the ignition lead at the back, see diagram 11.6.  
 Disconnect the white cable at the overhear cut off.  
 Disconnect the yellow cable from No.6 terminal of the thermostat.

Disconnect the live and neutral connections of the sequence board at the terminal strip and the board earth cable.  
 The board can now be eased off the two front fixing studs and removed from the rear location tags and support posts.

Refer to diagram 11.3 to reconnect.  
 Refit the control box as Section 11.4.

### 11.7 Thermostat

Ensure that the electrical supply is isolated.  
 Remove the controls cover by sliding it forward.  
 Remove the fascia by removing the four small screws, see diagram 11.1.

Pull off the thermostat knob.  
 Release or remove control box as in Section 11.4.  
 Remove the casing after unscrewing the two upper and two lower securing screws, see diagram 11.7.

Remove the screw and nut securing the capillary clips to the control box to release the capillaries, then pull the surplus through the hole in the back panel.

Remove the retaining clip that secures the phials into the pocket then remove the phial and coil.

Feed the phial capillary through the hole in the back panel and pull clear at the bottom.

Disconnect the electrical connectors at the thermostat. Remove the two screws securing the thermostat to remove from control box.

Refer to diagram 11.3 when reconnecting.  
 Refit the control box as in Section 11.4.

When fitting thermostat, push the phial upward at the rear right hand side of the boiler into the guide until it is visible and can be passed through the sealing angle hole in the back panel, pulling available capillary through the holes.

When replacing the phial smear it with heat sink compound supplied, before replacing and secure in the pocket with the retaining clip, see diagram 11.7.

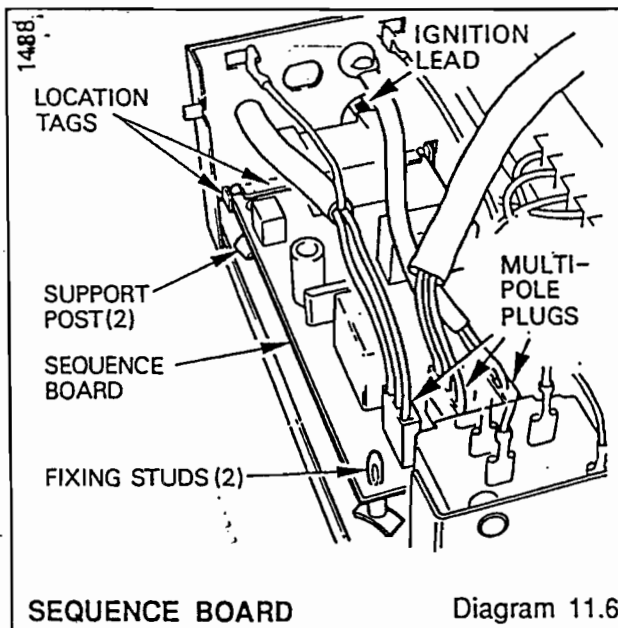

SEQUENCE BOARD

Diagram 11.6

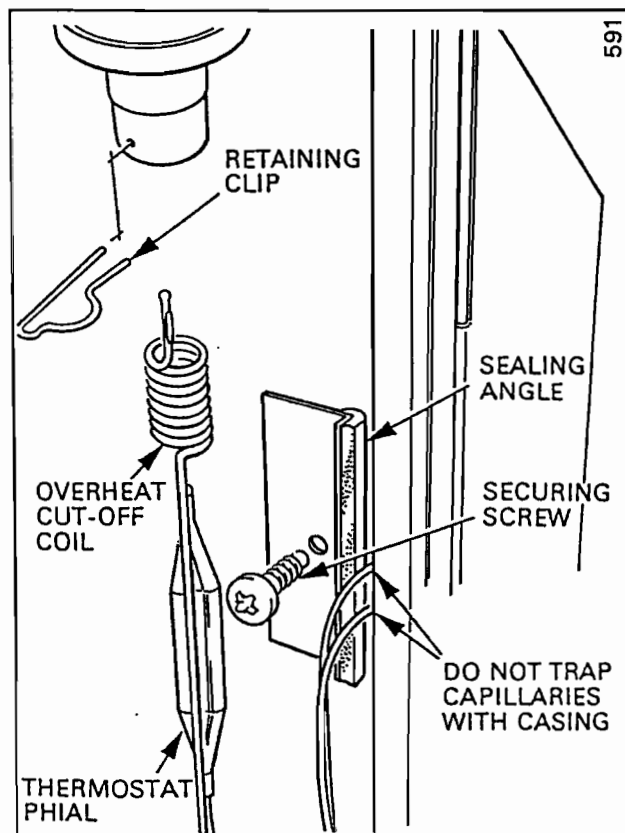

THERMOSTAT PHIAL

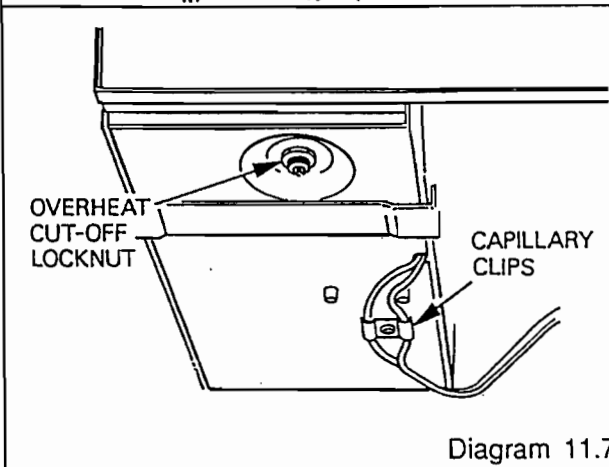

Diagram 11.7

## 11 Replacement of Parts

Feed surplus capillary back through the hole in the back panel before fitting sealing angle.

### 11.8 Overheat Cutoff

Ensure that the electrical supply is isolated.

Remove the controls cover by sliding it forward.

Release or remove the control box as Section 11.4.

Remove the casing and sealing angle as in Section 11.7.

Release the capillaries and pull surplus through as in Section 11.7.

Remove the retaining clip and pull out both phial and coil, see diagram 11.7. Feed the overheat cutoff coiled capillary through the hole in the back panel.

Disconnect the electrical connectors at the overheat cutoff, noting their position.

Remove the locknut to release the cutoff from the control box.

When fitting overheat cutoff, push the coiled capillary upward at the rear right hand side of the boiler into the guide until it is visible and can be passed through the sealing angle hole in the back panel, pulling all available capillary through the hole.

Position the coiled capillary at the top and the thermostat phial below it. Smear both with heat sink compound supplied, before replacing and securing in the pocket with the retaining clip, see diagram 11.7.

Feed surplus capillary back through the hole in the back panel before fitting the sealing angle.

After securing and connecting the cutoff press the reset button, see diagram 8.1.

Refit the control box as Section 11.4.

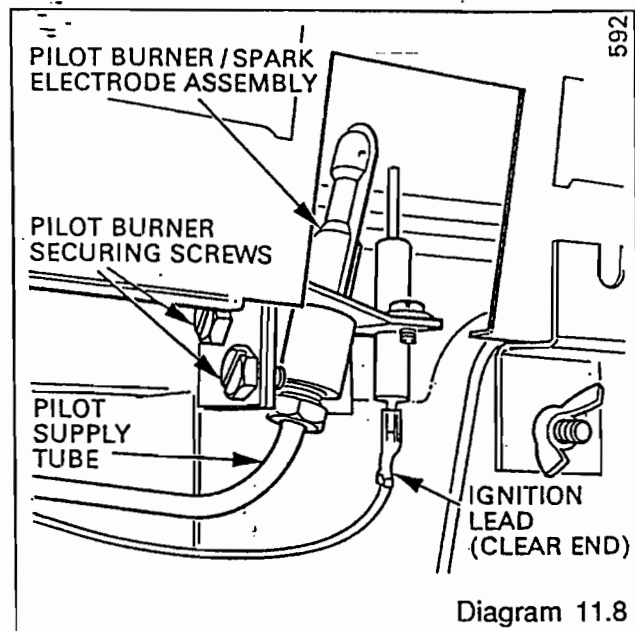

### 11.9 Ignition Lead

Ensure that the electrical supply is isolated.

Remove the controls cover by sliding it forward.

Remove the casing as in Section 11.7.

Release or remove the control box as Section 11.4.

Pull off the ignition lead at the connection at the back of the sequence board and electrode, see diagrams 11.6 and 11.8.

Remove one of the sealing angle where the lead passes through the back panel and replace the lead feeding it through in the same way as the original, securing it to the pilot supply tube by passing through the plastic tubing guides.

Fit the clear insulated end to the electrode.

Refit the control box as Section 11.4.

### 11.10 Pilot Burner/Electrode Assembly

Ensure that the electrical supply is isolated.

Remove the controls cover by sliding it forward.

Remove the casing as in Section 11.7.

Pull off ignition lead from the electrode, see diagram 11.8. Take care not to damage the lead insulation.

Disconnect the pilot supply tube at the base of the pilot burner and ease out from the pilot burner.

Remove the two screws securing the pilot burner/electrode assembly to the main burner and lift off.

Fit new pilot/electrode assembly and check the spark gap, see diagram 8.3.

Observe that the pilot flame is correct, see diagram 8.3. If any adjustment is required, turn pilot adjusting screw clockwise to decrease, see diagram 8.1. The pilot gas rate is normally fully open.

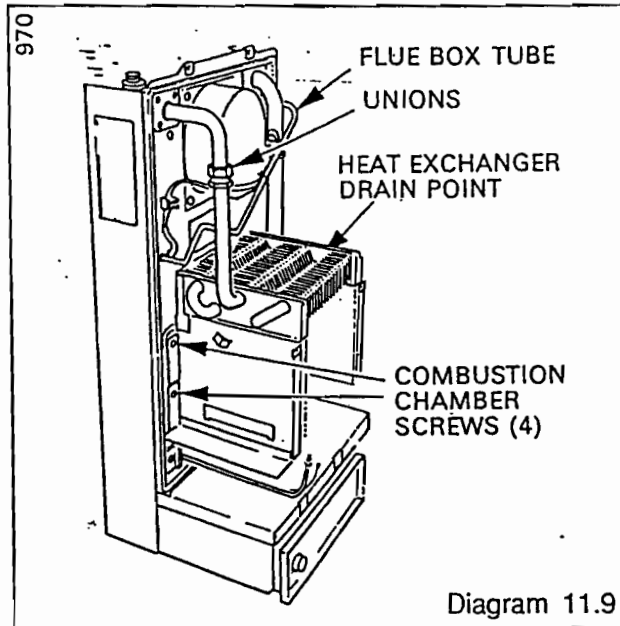

### 11.11 Fan Assembly

Ensure that the the electrical supply is isolated.

Remove the controls cover by sliding it forward.

Remove the casing as in Section 11.7.

Disconnect the cables to the fan, at the two way terminal strip and at the earth connection.

Release the cables from the support clip.

Remove the screw and clip securing flue box tube to fan casing.

Remove the three screws securing the fan assembly and it is free to be replaced by withdrawing forward and upward. Do not disturb the position of the flue box tube, see diagram 11.9.

Refit plastic clip to route and support the cables.

### 11.12 Heat Exchanger Body

Ensure that the electrical supply is isolated.

Remove the controls cover by sliding it forward.

Remove the casing as Section 11.7.

Drain the boiler circuit of water at the drain off cock(s). A drain point is provided for draining residual water in the boiler, see diagram 11.9.

Remove the flue hood and combustion chamber front panel, as in Section 9.1.

## 11 Replacement of Parts

Remove the burner and cover the pilot as Section 9.1.

Remove the retaining clip and thermostat phials as Section 1.17.

Remove the four screws securing the combustion chamber sides to the back plate, see diagram 11.9 then lower the combustion chamber taking care not to damage the insulation.

Disconnect the flow and return unions above the heat exchanger.

The heat exchanger assembly can then be removed and replaced.

Replace the heat exchanger. Locate the lugs on the combustion chamber sides into slots in the side plates of the heat exchanger.

Lift the heat exchanger and combustion chamber together and secure with the four screws to the back plate. The baffle/air tube assembly is also secured by the lower left hand screw.

When replacing the combustion chamber front panel, loosely fit screws until the flue hood has been secured.

Feed that capillaries as in Section 11.7, then smear the thermostat phial and overheat cutoff coil with heat sink compound supplied.

Make sure that coil and phial are fully pushed into the pocket and are retained by the clip, see diagram 11.7.

When replacing the flue hood make sure that a good seal is made to the back panel by replacing the two screws at the rear then the two hook bolts and wing nuts at the front. Do not overtighten the wing nuts.

### 11.13 Combustion Chamber Insulation

Gain access to the combustion chamber, as Section 9.1.

Remove the screw securing the front insulation and slide out, see diagram 11.10.

Each side insulation can be removed by sliding forward.

Follow the relevant instruction in Section 9.1 to remove the burners.

Release and lower the combustion chamber as in Section 11.12.

The rear insulation can then be lifted out.

When replacing the combustion chamber front panel and flue hood refer to Section 11.12.

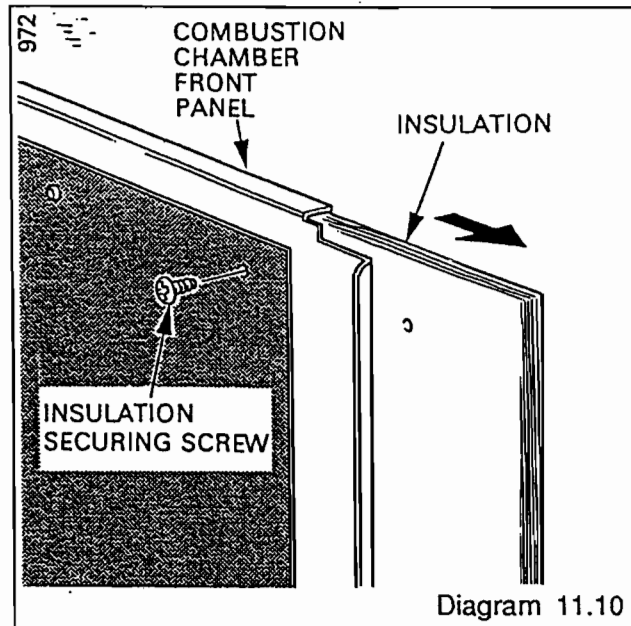

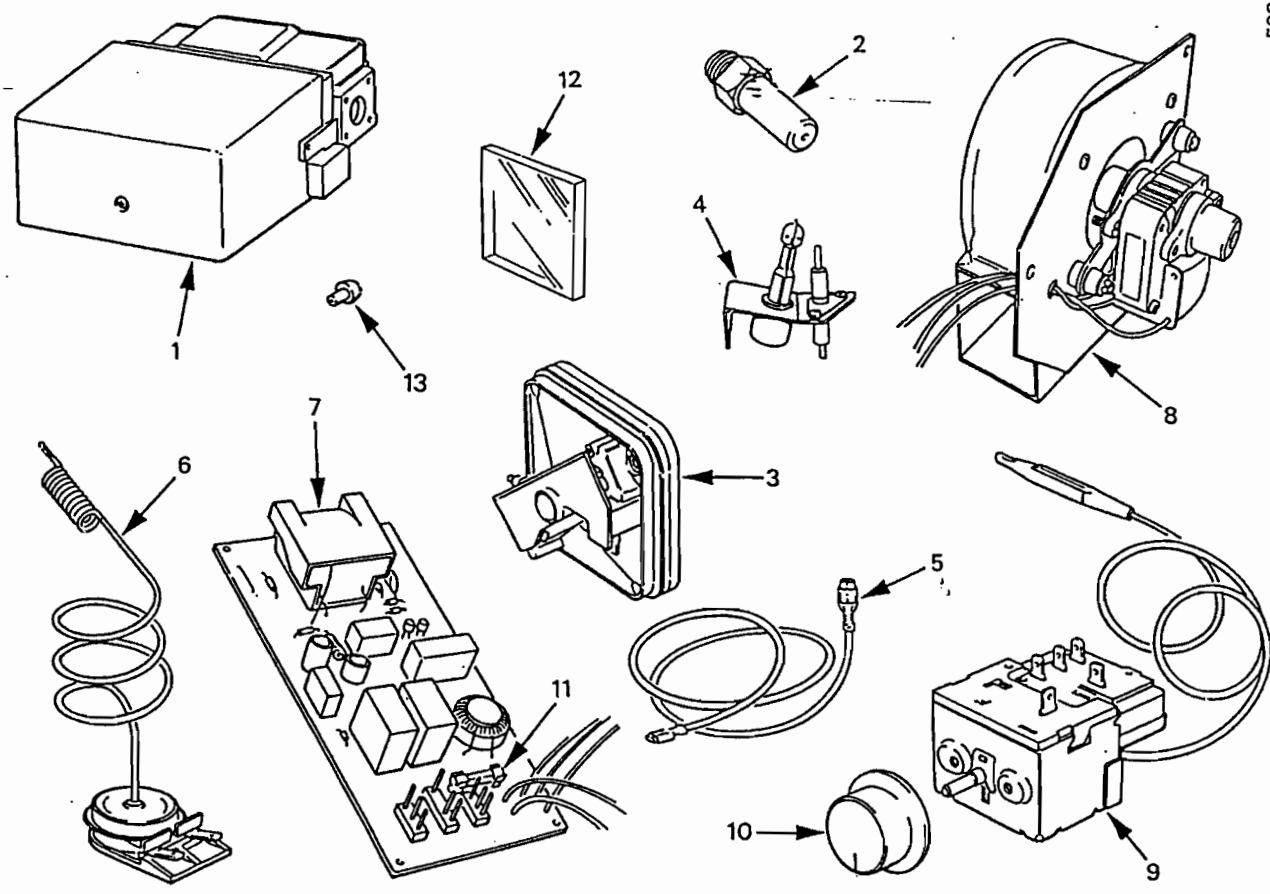

Diagram 12.1

Key No	Glow-worm Part No	Description	GC Part No
1	417517	Gas control assembly	334 702
2	203021	Injector - 35F - 2.85mm	334 641
2	203059	Injector - 45F - 3.4mm	312 779
2	203020	Injector - 55F - 3.55mm	334 594
3	202005	Air pressure switch	395 802
4	417268	Pilot burner/electrode assembly	334 602
5	WW4606	Ignition lead	334 621
6	202505	Overheat cutoff assembly	395 799
7	417281	Sequence board	334 623
8	417135	Fan assembly	334 610
9	202504	Thermostat assembly	395 779
10	416144	Thermostat knob assembly	355 401
11	202015	Fuse - 1A 5x20mm	334 750
12	411194	Sight glass	355 153
13	204194	Air restrictor - marked "A"	312 780

### 12.1 Part Identification

The key number in the first column of the list will help identify each part in diagram 12.1.

### 12.2 Ordering

When ordering spare parts quote the part number, description and the appliance name and its serial number off the plate visible after the controls cover has been removed by sliding it forward.

Gas undertakings will also require the GC number of the part and appliance.