

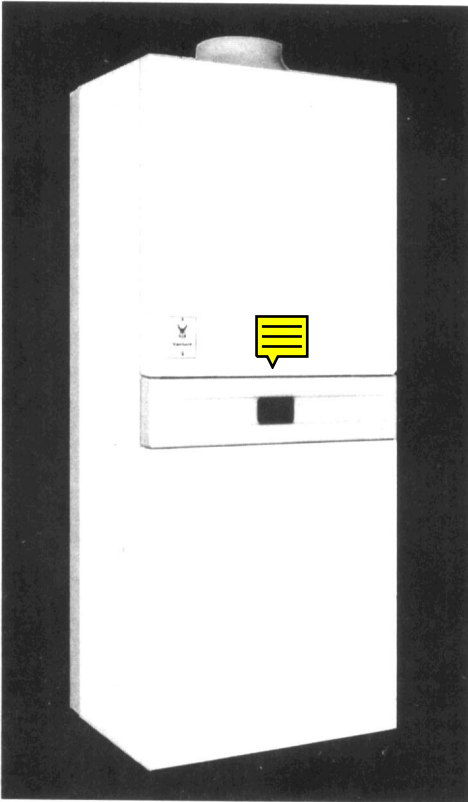

Vaillant

Instructions for Installation and Servicing



Vaillant
Combined appliances
for heating
and
domestic hot water

VCW 20/1 T3 W

GC-No. 47 044 03

VCW 25/1 T3 W

GC-No. 47 044 05

VCW-sine 18 T3 W

GC-No. 47 044 01

Central heating
Domestic hot water

This appliance shall be installed in accordance with the relevant Codes of Practice by British Gas or by an authorized installer (CORGI member)

These instructions should be left near the gas meter when the installation is completed.

80 53 74 GB 02

Contents

1. Introduction	Page 2
2. Construction of appliance	2
3. General requirements	4
4. Installation of boiler	7
5. Water circulation system	20
6. Commissioning and testing	23
7. Assembling	25
8. Servicing of combi heater	27
9. Fault finding	46
10. Short list of ports	61
11. Technical data	64

1 Introduction

The Vaillant combi boiler is a wall-mounted natural draught open-flued (or in the case of VCW-sine, room-sealed) boiler with built in instantaneous domestic hot water heater.

Output ratings are shown in "Technical Data".

The boiler is designed for use in a sealed or open vented system with pumped circulation and includes the instantaneous hot water system.

Circulating pump, expansion vessel (for sealed system only), terminal box, control and safety devices are provided with the appliance.

Note to Installers

In hard water areas we recommend the cold supply to the appliance is via a scale reducer.

2 Construction of Appliance

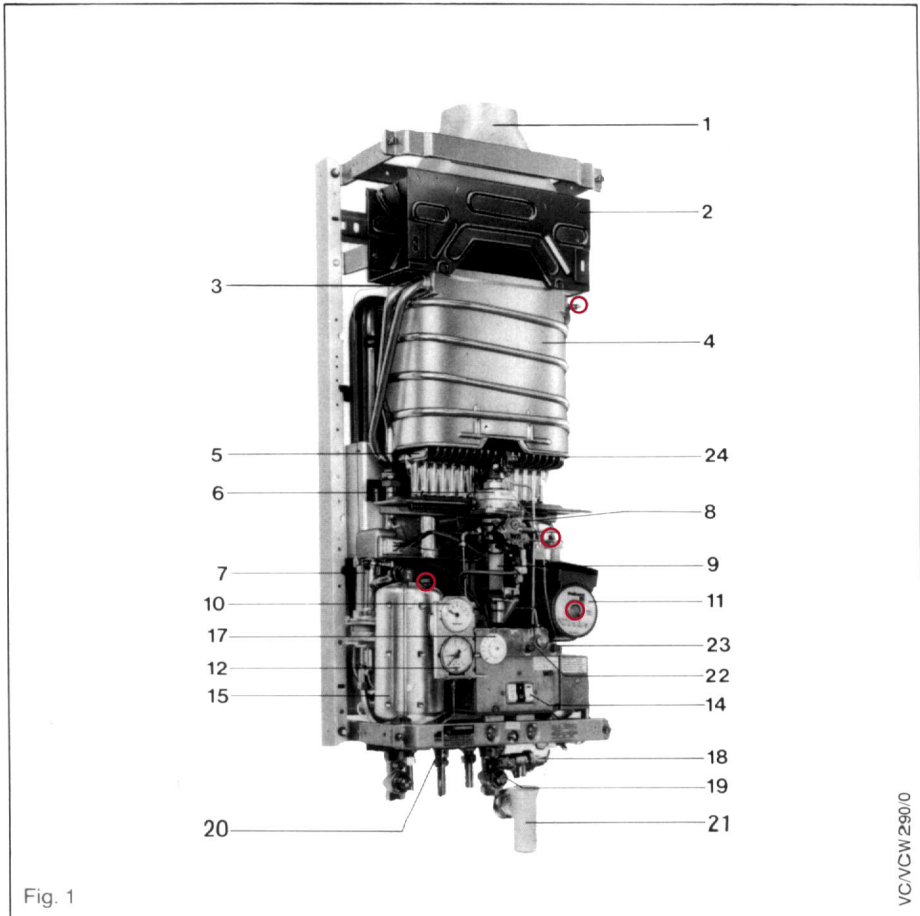

- | | | | |
|----|-----------------------------------|----|---|
| 1 | Flue connection | 13 | Terminal box |
| 2 | Down draught diverter | 14 | Switch board (main switch, heating switch, domestic hot water switch) |
| 3 | Sensor of overheat cut-off device | 15 | Domestic heat exchanger |
| 4 | Main heat exchanger | 17 | Flow thermostat |
| 4a | Combustion chamber | 18 | Pressure relief valve |
| 5 | Main burner | 19 | Service cock |
| 6 | Gas governor | 20 | Gas service cock |
| 7 | Flow switch | 21 | Overflow (optional extra) |
| 8 | Differential valve | 22 | Push button start |
| 9 | DC solenoid | 23 | Push button stop |
| 10 | Flow thermometer | 24 | Pilot burner |
| 11 | Pump with automatic air vent | 25 | Piezo unit |
| 12 | Pressure gauge | | |

○ air vent points

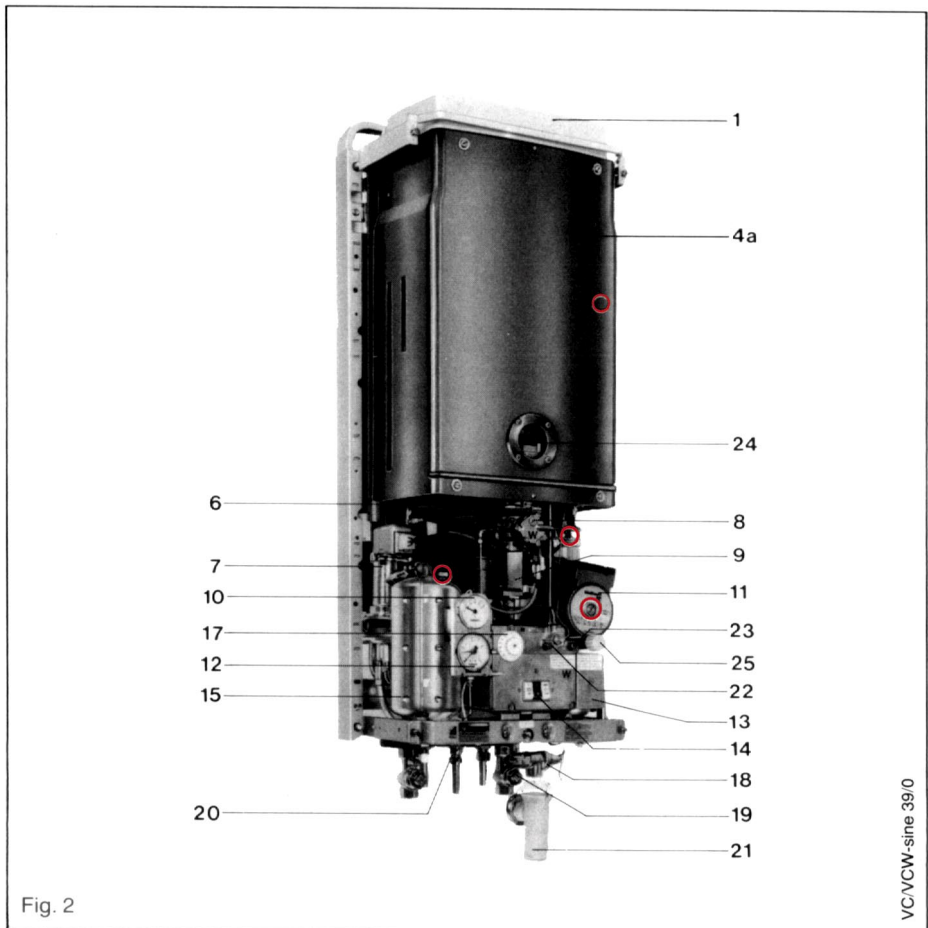

Fig. 2

3 General requirements

3.1 Related documents

The installation of the combi boiler must be in accordance with the relevant requirements of the Gas Safety Regulations*), building regulations, I.E.E. Regulations, and the byelaws of the local Water Undertaking.

It should be in accordance also with any relevant requirements of the local authority and the relevant recommendations of the following British Standard Codes of Practice:

- CP 331 Installation of pipes and meters for town gas,
Part 3: Low pressure installation pipes.
- BS 5376 Selection and installation of gas space heating (1. and 2. family gases).
Part 2 Boilers of rated input not exceeding 60 kW.
- BS 5449 Central heating for domestic premises.
Part 1 Forced circulation hot water systems.

- CP 342 Centralized hot water supply.
Part 1 Individual dwellings,
Part 2 Buildings other than individual dwellings.
- BS 5440 Flues and air supply for gas appliances of rated input not exceeding 60 kW (1. and 2. family gases).
Part 1 Flues
Part 2 Air supply.
- BS 5446 : 1979
Installation of gas hot water supplies for domestic purposes.

We like to draw your attention to the fact that any connection for the filling or replenishing of a sealed primary circuit from a supply pipe is conditional upon a water undertaking seeking and obtaining consent for a relaxation of its Byelaws 3 and 8 (1) from the Secretary of State.

*) Gas Safety Regulation, 1972:

It is the law that all gas appliances are installed by competent persons in accordance with the above regulations. Failure to install appliances correctly could lead to prosecution. This is in your own interest and that of safety to ensure that the law is complied with.

3.2 Location

3.2.1 VCW-sine (B.F. Appliance)

The location chosen for the combi boiler must permit the provisions of a satisfactory flue terminal. The location must also provide adequate space for servicing and air circulation around the heater. The combi boiler may be installed in any room, although particular attention is drawn to the requirements of the I.E.E. Regulations and, in Scotland, the electrical provisions of the building regulations, with respect to the installation of the combi boiler in a room containing a bath or shower.

Where the installation of the combi boiler will be in an unusual location, special procedures may be necessary and BS 5546 and BS 5376 : 2 give detailed guidance on this aspect.

A compartment used to enclose the combi boiler must be designed and constructed specifically for this purpose. An existing cupboard or compartment may be used provided that it is modified for the purpose.

Details of essential features of cupboard/compartment design including airing cupboard installations are given in BS 5376 : 2.

3.2.2 VCW (O.F. Appliance)

The location chosen for the combi boiler must permit the provision of a satisfactory flue and adequate air supply. The location must also provide adequate space for servicing and air circulation around the appliance.

The combi boiler must not be installed in a room containing a bath or shower. In addition, it is recommended that the combi boiler should not be fitted in a bedroom. Where the installation of the combi boiler will be in an unusual position, special procedures may be necessary and BS 5376 : 2 and BS 5546 give detailed guidance on this aspect. A compartment used to enclose the combi boiler must be designed and constructed specifically for this purpose. An existing cupboard or compartment may be used provided that it is modified for the purpose.

Details of essential features of cupboard/compartment design including airing cupboard installations are given in BS 5376 : 2.

3.3 Gas supply

3.3.1 Service pipes

The local gas region should be consulted at the installation planning stage in order to establish

the availability of an adequate supply of gas.

An existing service pipe must not be used without prior consultation with the local gas region.

3.3.2 Meters

A gas meter is connected to the service pipe by the local gas region or a local gas region contractor.

An existing meter should be checked to ensure that it is capable of passing an additional 2.95 m³/h (106 CFH) before the VCW 20 (or 3.38 m³/h (122 CFH) before the VCW 25 or 2.47 m³/h (89 CFH) before the VCW-sine 18) is installed.

3.3.3 Installation pipes

Installation pipes should be fitted in accordance with CP 331 : 3.

Pipework from the meter to the combi boiler must be of an adequate size. Do not use pipes of a smaller size than the combi boiler gas connection.

The complete installation must be tested for soundness as described in the above Code.

3.4 Flue system

Detailed recommendations for fluing are given in BS 5440 : 1. The following notes are intended to give general guidance.

3.4.1 VCW-sine (B.F. Appliance)

The boiler must be installed so that the flue terminal is exposed to the external air.

Termination should be on a clear expanse of wall;

the terminal being preferably not less than 600 mm (2 ft.) away from a corner, a recess or a projection.

Do not install the terminal:

- Within 300 mm (1 ft.) measured vertically from the bottom of an openable window, air vent, or any other ventilation opening.
- Within 300 mm (1 ft.) above adjacent ground level.
- Within 600 mm (2 ft.) of any surface facing the terminal.
- Immediately beneath eaves or a balcony.

Where the lowest part of the terminal is less than 2 m (6.6 ft.) above the level of any ground, balcony, flat roof or place to which people have access, the terminal must be protected by a guard of durable material. A terminal protective guard is available as an optional extra with the combi boiler. The air inlet/products outlet duct and the terminal of the boiler must not be closer than 50 mm (2 in.) to combustible material. Detailed recommendations on protection of combustible material are given in BS 5440 : 1.

3.4.2 VCW (O.F. Appliance)

Detailed recommendations for fluing are given in BS 5440 : 1. The following notes are intended to give general guidance.

The cross sectional area of the flue fitted to the combi boiler must be not less than the area of the flue outlet of the appliance. An adapter is supplied to allow the fitting of 125 mm steel flue pipe or 125 mm light asbestos cement flue pipe.

When fitting flue pipes a split socket connector must be fitted to ensure easy disconnection of the flue pipe (see page 13 fig. 16).

Flue pipes and fittings should be constructed from one of the following materials:

- Asbestos cement,
- Aluminium or stainless steel,
- Cast-iron acid-resistant vitreous enamel lined.

If double-walled flue pipe is used it should be of a type acceptable to British Gas.

If a chimney is used it preferably should be one that is composed of or lined with a nonporous acid-resistant material. (Chimneys lined with salt-glazed earthenware pipes are acceptable if the pipes comply with BS 65 and 540 : 1.) A flue pipe constructed from one of the materials in a) to c) above should form the initial connection to lined chimneys. Where a chimney is to be used which is not composed of or lined with a non-porous acid-resistant material it should be lined with a stainless steel flexible flue liner or any other liner that is of a type acceptable to British Gas. The internal diameter of the liner must not be less than shown in the technical data and the number of joints must be kept to a minimum. If the flue liner is not to be connected directly to the combi boiler draught diverter a flue pipe which is constructed from one of the materials in a) to c) above should form the connection between the draught diverter and flue liner.

Before connecting the combi boiler to, or inserting a liner into, a flue that has been previously used, the flue must be thoroughly swept clean of any soot and loose material. If a register plate, restrictor plate, damper etc. is fitted in the flue, it must be removed before connecting the combi boiler to, or inserting a liner into, the flue.

The flue should terminate in accordance with the relevant recommendations given in BS 5440 : 1, table 4.

A terminal of a type that has been tested and found satisfactory by British Gas should be fitted at the flue outlet.

The point of termination must not be within 600 mm (2 ft.) of an openable window, air vent or any other ventilation opening.

3.5 Air supply

Detailed recommendations for air supply are given in BS 5440 : 2. The following notes are intended to give general guidance.

minimum effective area of permanent air vent(s) is specified below and is related to the maximum rated heat input of the unit.

3.5.1 Room or internal space air supply

The room or space in which the boiler is located must have a permanent air vent. This vent must be either direct to the outside air or to an adjacent room or internal space which must itself have a permanent air vent of at least the same size direct to the outside air. The

Appliance	cm ²	in. ²
VCW 20/1	108	16
VCW 25/1	130	20

The balanced flued combi boiler, VCW-sine, does not require the room or internal space to have a permanent air vent.

3.5.2 Cupboard or compartment air supply

Where the combi boiler is to be installed in a cupboard or compartment, permanent air vents are required (for cooling purposes and in the case of open flued appliances also for combustion and flue dilution) in the cupboard or compartment at high and low level. These air

vents must either communicate with the room or internal space or be direct to outside air.

The minimum effective areas of the permanent air vents required in the cupboard or compartment are specified below (Tab. 1) and are related to the maximum rated heat input of the unit.

Pos. of air vents		Air vent areas			
		Air from room or internal space		Air direct from outside	
		cm ²	(in ²)	cm ²	(in ²)
High Level	VCW 20/1	280	(42)	140	(21)
	VCW 25/1	320	(50)	160	(25)
	VCW-sine	235	(36,5)	120	(18,5)
Low Level	VCW 20/1	560	(84)	280	(42)
	VCW 25/1	640	(100)	320	(50)
	VCW-sine	235	(36,5)	120	(18,5)

Tab. 1

Note: Both air vents must communicate with the same room or internal space or must be both on the same wall to the outside air.

Where cupboard or compartment air vents communicate with the room or internal space the room or internal space must itself have a permanent air vent(s) as specified in 3.5.1.

3.5.3 Effect of an extract fan

If there is any type of extract fan fitted in the premises there is the possibility that if adequate air inlet area from outside is not provided spillage of the products from the open flued

combi boilers flue could occur when the extract fan is in operation. Where such installations occur a spillage test as detailed in BS 5440 : 1 must be carried out and any necessary action taken.

3.6 Water circulation system

Detailed recommendations for the water circulation system are given in BS 5376 : 2, BS 5449 : 1 (for small bore and micro bore central heating systems) and CP 342. The following notes are of particular importance. Pipework not forming part of the useful heating surface should be insulated to help prevent heat loss and possible freezing, particularly where pipes

are run through roof spaces and ventilated underfloor spaces.

Draining taps must be located in accessible positions which permit the draining of the whole system including the combi heater and the hot water system. Draining taps should be at least 1/2 in. nominal size and be in accordance with BS 2879.

3.7 Electrical supply

Wiring external to the combi boiler must be installed in accordance with the I.E.E. Regulations and any local regulations which apply.

The combi boiler is supplied for 220/240 V,

50 Hz. Fuse rating is 3 A.

The combi boiler has to be connected direct to the mains electricity supply using the internal terminal box.

For wiring instructions see paragraph 4.7.

4 Installation of boiler

4.1 General

The combi boiler is to be wall-mounted and a vertical flat area of wall is required which must measure as shown on template.

This area does not include clearance for installation and servicing. If the appliance is fitted on a wall of combustible material, the wall should be protected by a sheet of fireproof material.

In addition, a minimum clearance of 400 mm

(16 in.) must be available at the front of the appliance to enable the combi boiler to be serviced.

Service clearance of 150 mm (6 inches) either side is required.

For the open flue type appliances VCW 20/1 and 25/1 an additional clearance is required for the flue. The combi boiler is supplied in 2 cartons, one containing the boiler, the other the installation accessories. An additional carton containing the terminal/duct assembly is delivered with the balanced flued appliance.

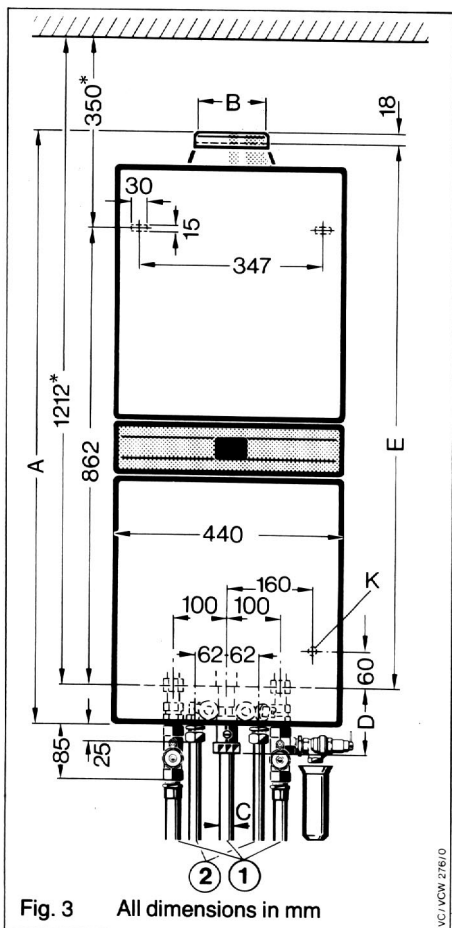

Type of appliance	VCW 20/1	VCW 25/1
A	1095 mm	1161 mm
B	130 mm 125 mm with adapter	
C	15 mm	22 mm
D	100 mm	107 mm
E	1014 mm	1080 mm
K	Electrical mains connection	
weight	59 kg	60 kg

*) Minimum distance required to remove expansion vessel. Installation may require another distance.

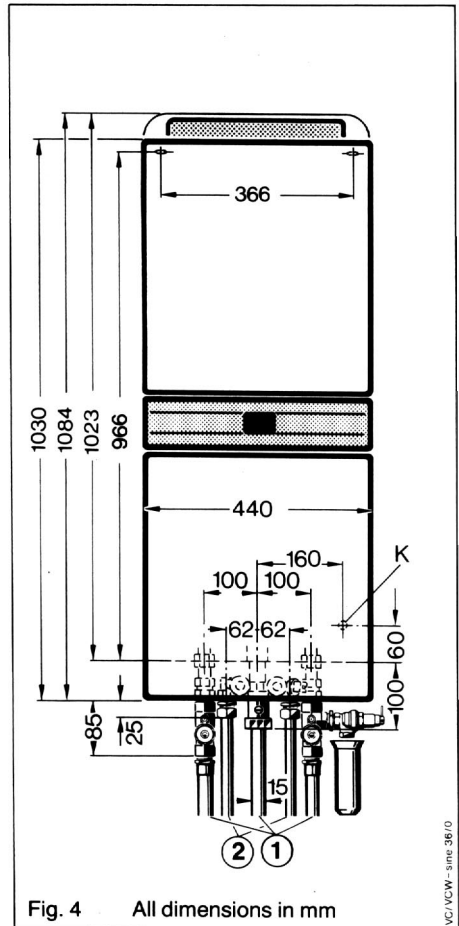
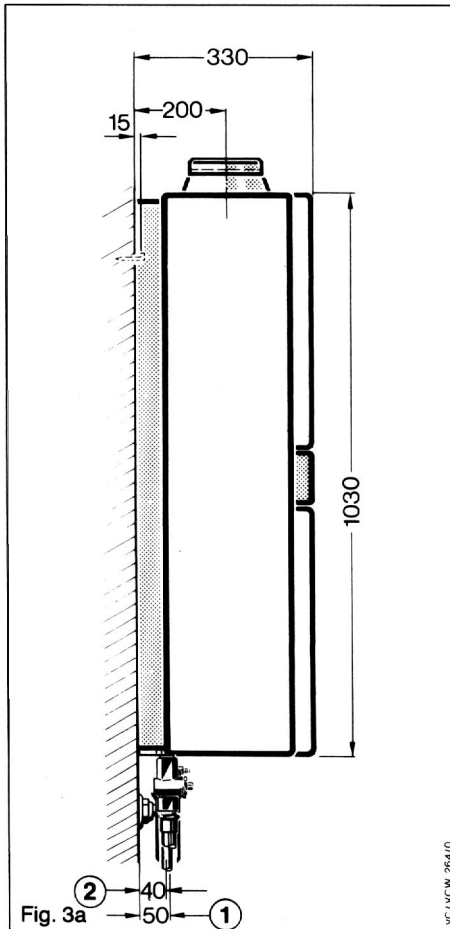

4.2 Fluing

For the installation of the flue set (wall case) of a room sealed combi boiler, we refer to the separate installation instructions No. 806901 included with every flue set.

4.3 Connection

A general view of pipework for gas and water connection is given in fig. 5.

The following procedure describes the installation.

The wall distance (to the finished wall) of pipework for gas and heating system is 50 mm and 40 mm for domestic water pipework.

1. Compression union (flow of heating system)
2. Service cock (flow of heating system)
3. Domestic hot water connection
4. Union (gas)
5. Gas service cock
6. Cold water connection with shut-off valve
7. Service cock (return of heating system)
8. Over flow (optional extra)
9. Pressure relief valve
10. Compression union (return of heating system)
11. Connection support
23. Frame of appliance (lower connection).

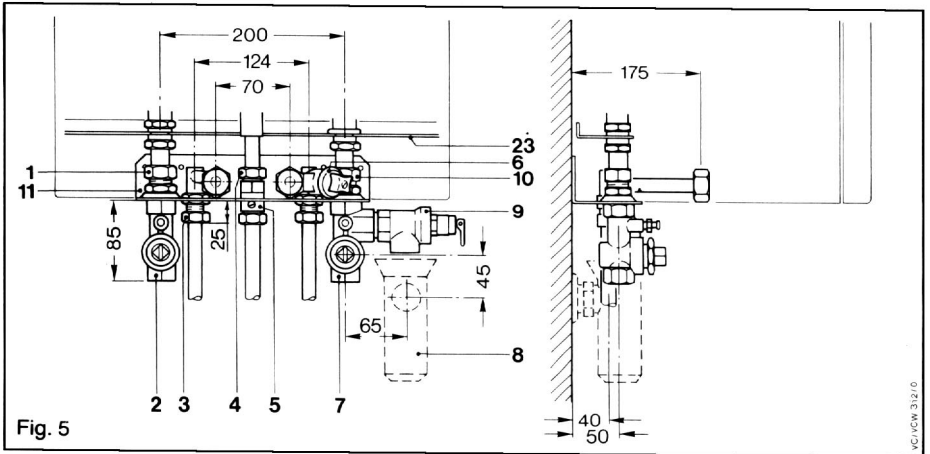
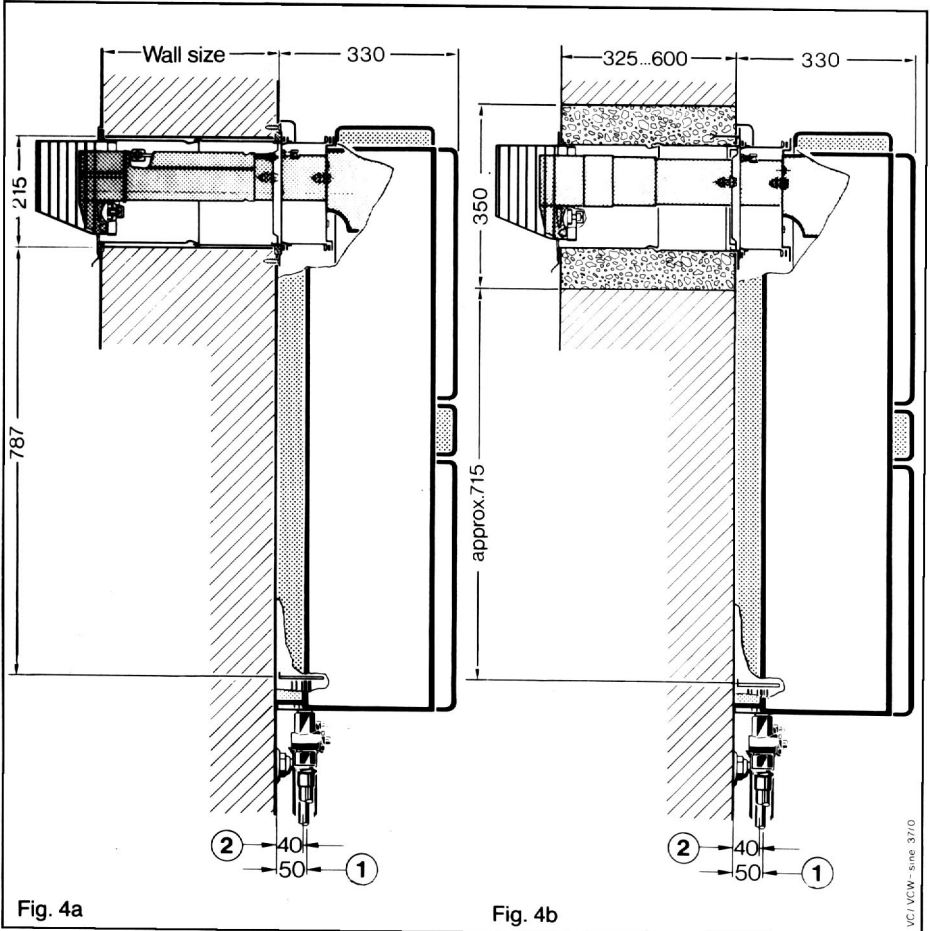

4.3.1 Installation aids

4.3.1.1 Open flued combi boiler

After fixing the connecting group to the wall put the template in position and mark positions of fixing holes.

The type of fixing used will depend on the type of wall.

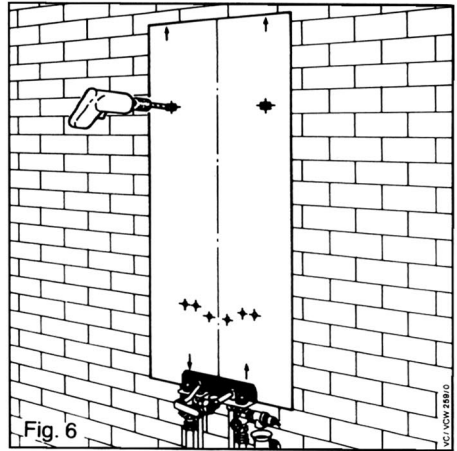

4.3.1.2 Room sealed combi boiler

After installing the terminal/duct assembly, hang the template on the fixing bolts (1) and drill the 3 holes with 8 mm (5/16 inches) diameter to fit the connecting group. Use the alternative fixing holes where necessary.

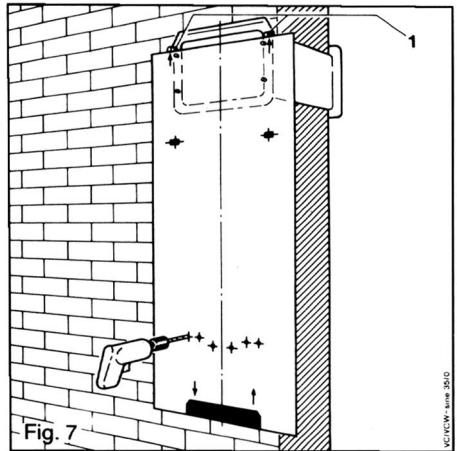

4.3.2 Domestic cold and hot water connection

- Flush out all foreign matter from the supply pipe before connecting to the connecting pipe.
- Fit the domestic mains water pipe to the right hand compression union (2) and the hot water pipe to the left hand compression union (3).
In hard water area the mains supply to union (2) should be via a scale reducer.
- Check domestic water system for soundness.

N.B. The combi boiler has a maximum working pressure of 10 bar. If water pressure exceeds this a pressure reducing valve will have to be fitted to cold water inlet.

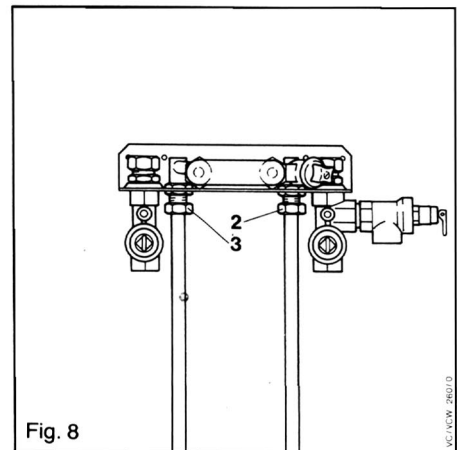

4.3.3 Connection of heating system

Heating system flow and return should be in 22 mm copper pipe and connected to the connecting group as shown in fig. 9.

Fill the heating system and test for soundness.

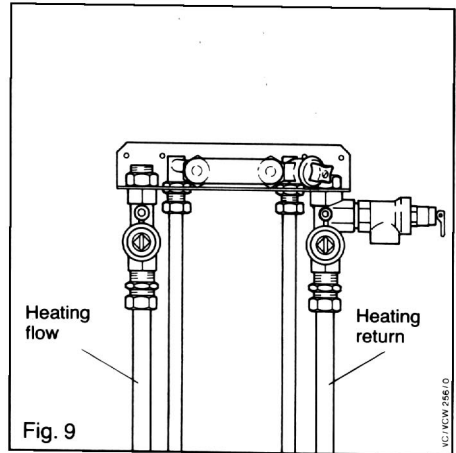

4.3.4 Pressure relief valve and overflow

The pressure relief valve, required for a sealed system, is included into the connecting group.

- Screw in the overflow (4) below the pressure relief valve into the drain line.
(To be available as an optional extra.)

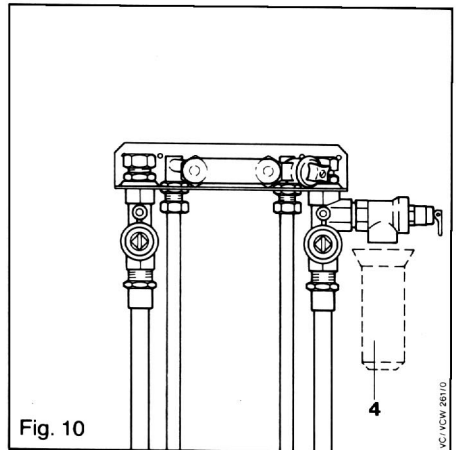

4.4 Fitting the appliance

Close service cocks (5), unscrew union nuts (6) and take off the olive-shaped plastic plugs. Refit union nuts (6) with brass compression rings (7). Close mains water service cock (8) and unscrew the union nuts (9).

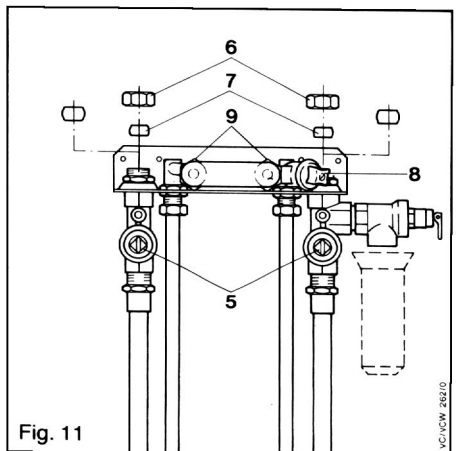

4.4.1 Open flued appliance

Unpack boiler from carton and remove side panels (as in 8.1.1.), lint arrester (as in 8.2.2) and packing aids as well as plastic caps from the connections. Insert the appliance with the connection tubes downwards into the compression unions of the service cocks and hang it on to the bolts(1) and fasten screws (10).

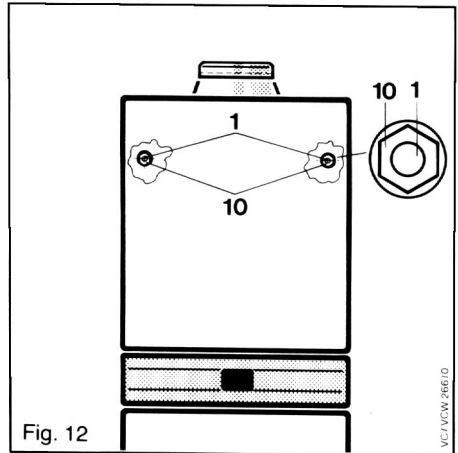

Fig. 12

Fasten compression unions (6) and union nuts (9), using the attached washers (11).

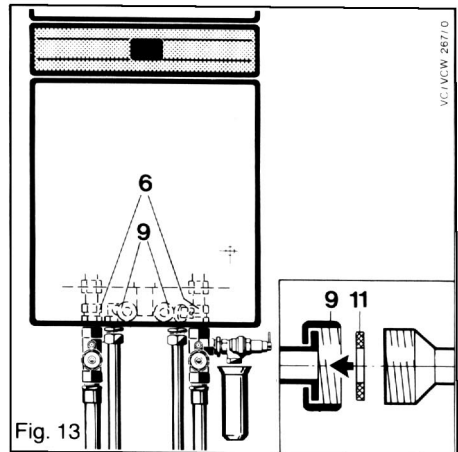

Fig. 13

4.4.2 Balanced flued appliance

Unpack boiler from carton and remove side panels (as in 8.1.1.) and packing aids as well as plastic caps from the connections. Fit the flue duct (20) with the 2 sheet metal screws (22) to the telescopic duct (16) of the terminal/duct assembly.

Insert the appliance with the connection tubes downward into the compression unions of the service cocks and hang it on to the threaded bolts of the wall case (1), fig. 14. Fasten nuts, compression unions (6, fig. 13) and union nuts (9, fig. 13) using the attached washers (11, fig. 13).

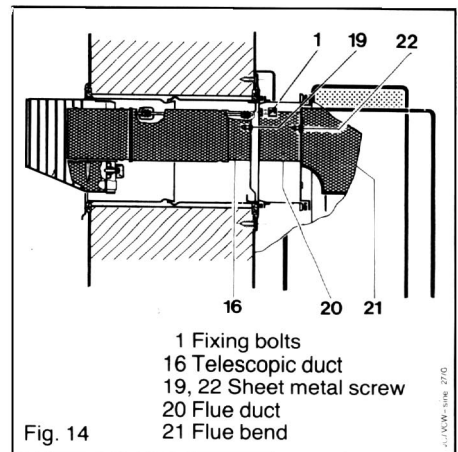

Fig. 14

4.5 Gas connection

Fit the gas service cock (5) to the appliance.

Clean out all foreign matter from the gas supply pipe before connecting to the service cock!

Connect the gas supply pipe to the service cock and tighten.

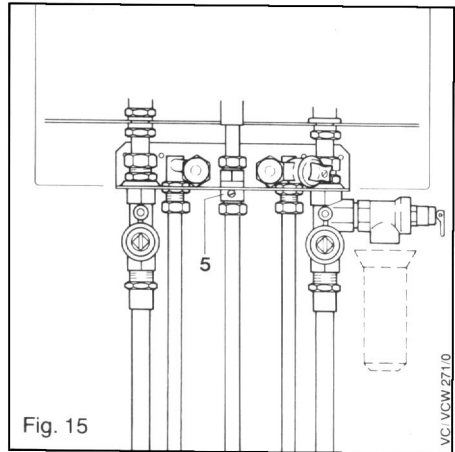

4.6 Flue connection (open flued)

Insert flue into the draught diverter after fitting the adapter provided.

A split socket connector must be fitted to ensure easy disconnection of the flue to simplify removal of the main heat exchanger.

- 21. Flue pipe
- 22. Draught diverter
- 22.a Collar of the draught diverter
- 24. Adapter
- 25. Split socket connector

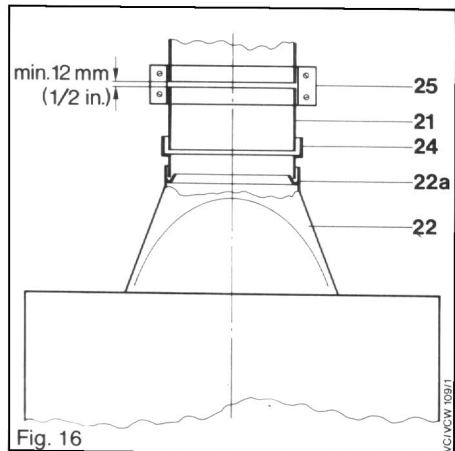

4.7 Electrical connections

Vaillant combi boilers are completely wired. It is only necessary to connect the electrical mains and the room thermostat. Connect to 220/240 V 50 Hz. electrical supply fused 3 A.

Warning! This appliance must be earthed.

After removing the terminal box cover connect the mains to the terminal (c) of the appliance in the manner indicated below. A cardboard label showing the correct mains connection to the terminals is in the terminal box. Please remove before connecting.

Do not connect the electrical supply to the pump terminals (b).

Full wiring diagrams for various control schemes are shown in fig. 21 to 24.

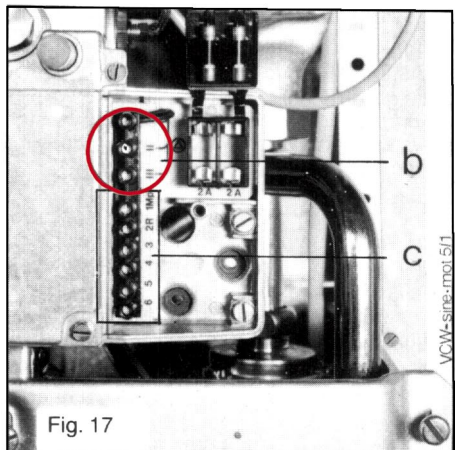

4.7.1 Connection of the mains cable

As shown on the figures the live conductor which is coloured brown must be connected to the terminal marked with a L on the appliance and to the terminal marked L or coloured red on the plug. The neutral wire coloured blue must be connected to the terminal marked with a N on the appliance and to the terminal marked N or coloured black on the plug. The earth wire coloured green and yellow must be connected to one of the two terminals marked ⊕ on the appliance and to the terminal marked with an E or symbol ⊕ or coloured green or green and yellow on the plug. If no room thermostat or timer is installed, terminal 3 and 4 must be linked.

- a. Fuses 2 A (delay action).
- b. Terminals for pump regulating.
- c. Terminals for appliance input connections.

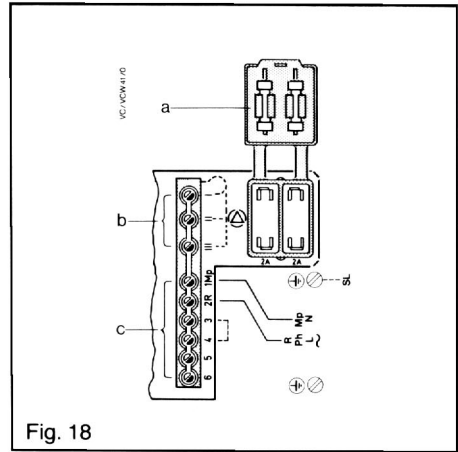

Fig. 18

4.7.2 Connection of Vaillant room thermostat with clock (no. 394)

Connection of room thermostat is made to the terminals 3 and 4. It is recommended to install a Vaillant room thermostat (RT) with accelerating resistance. The room thermostat must be installed on an inner wall which is influenced neither by current of air nor by the sun, in the living room. During the installation of the room thermostat the manufacturer's indications must be followed. For the sake of economy and comfort the Vaillant combi boiler should be regulated by a room thermostat with accelerating resistance. If the room thermostat is not connected, to operate the heating system for testing purposes after the installation, the unit can be operated by provisional application of a bridge between the terminals 3 and 4. When the room thermostat is wired in this bridge must be removed.

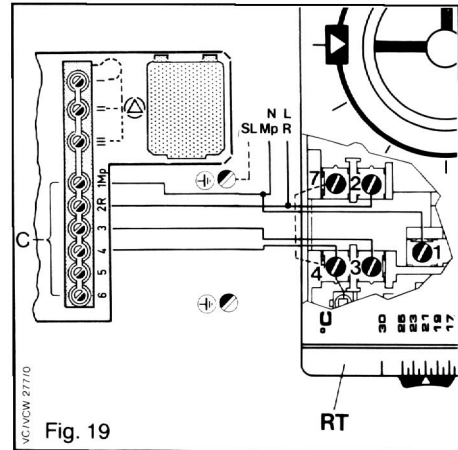

Fig. 19

4.7.3 Pump control

The pump may be controlled in one of three ways (see fig. 20):

Setting I (as supplied)

For use with clock and room thermostat systems. Pump is switched off by clock or room thermostat.

Setting II

For use with thermostatic radiator valve systems. Pump is switched off by clock or gas valve switch when gas valve closes.

Setting III

Pump runs permanently and is not affected by external controls.

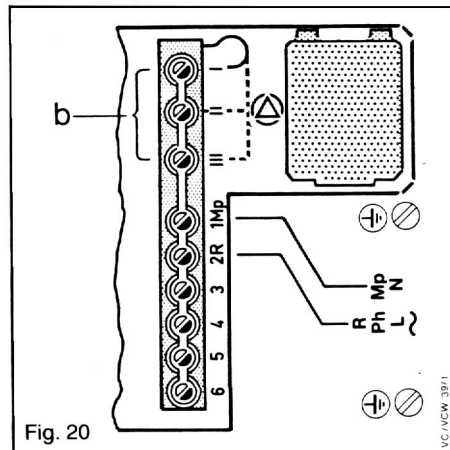

Fig. 20

4.7.4 Thermostatic radiator valves

Where TRV's and a clock are used the switching side of the clock is connected between terminals 3 and 4.

Where no clock is used a wire bridge must be inserted between terminals 3 and 4.

Set the pump control to position II.

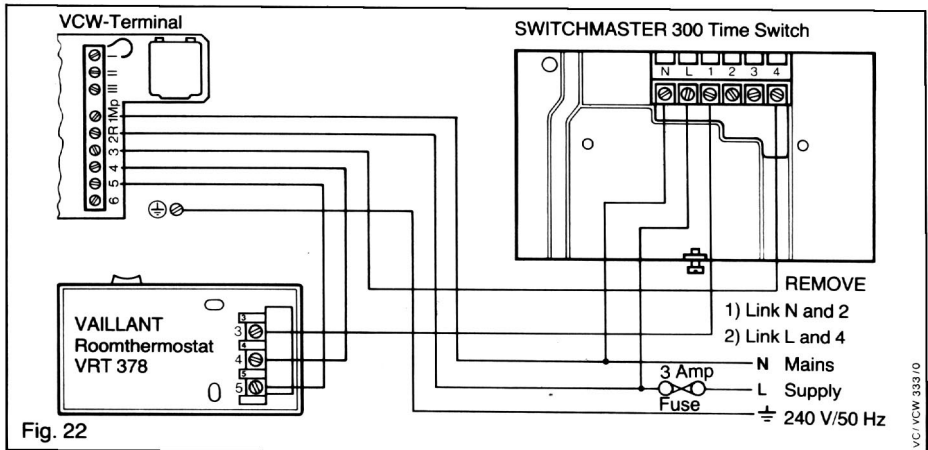
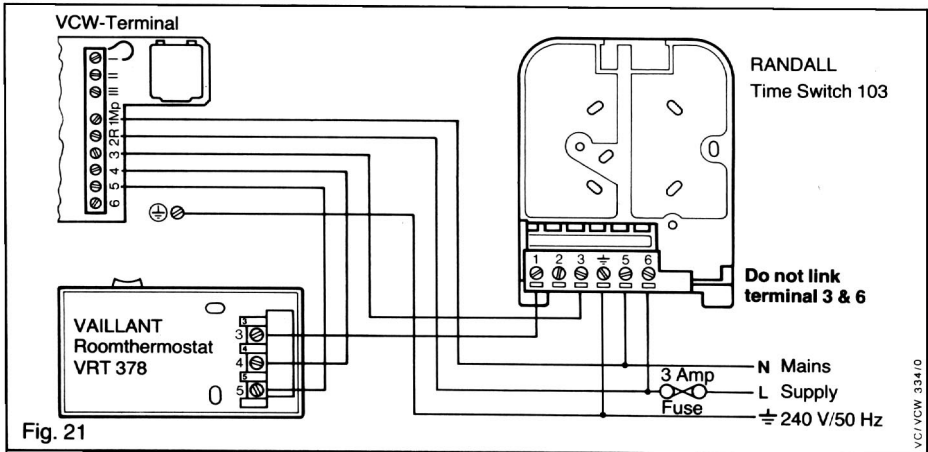

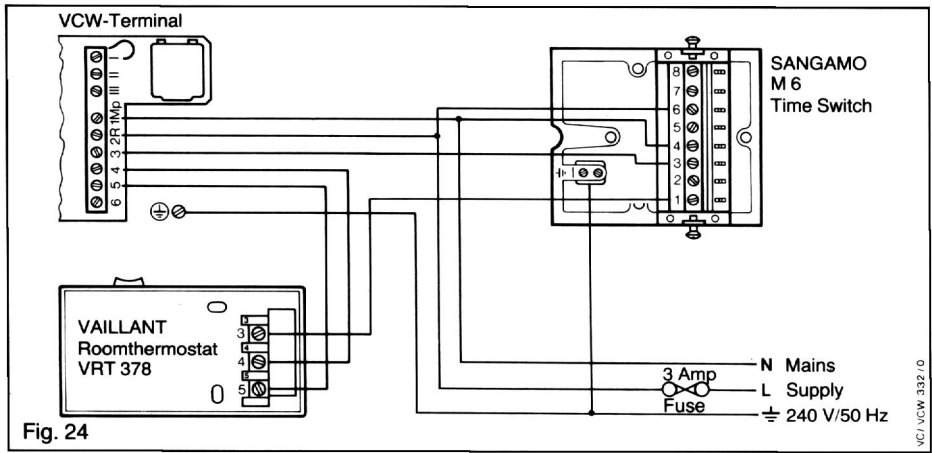
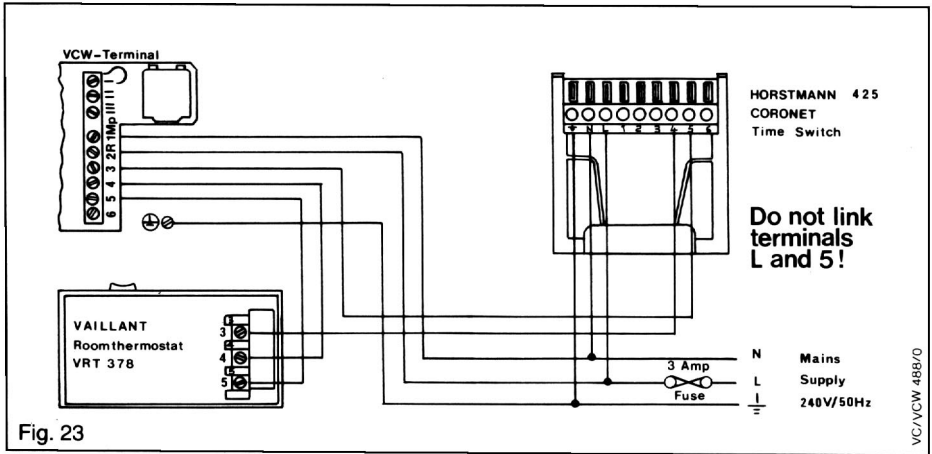

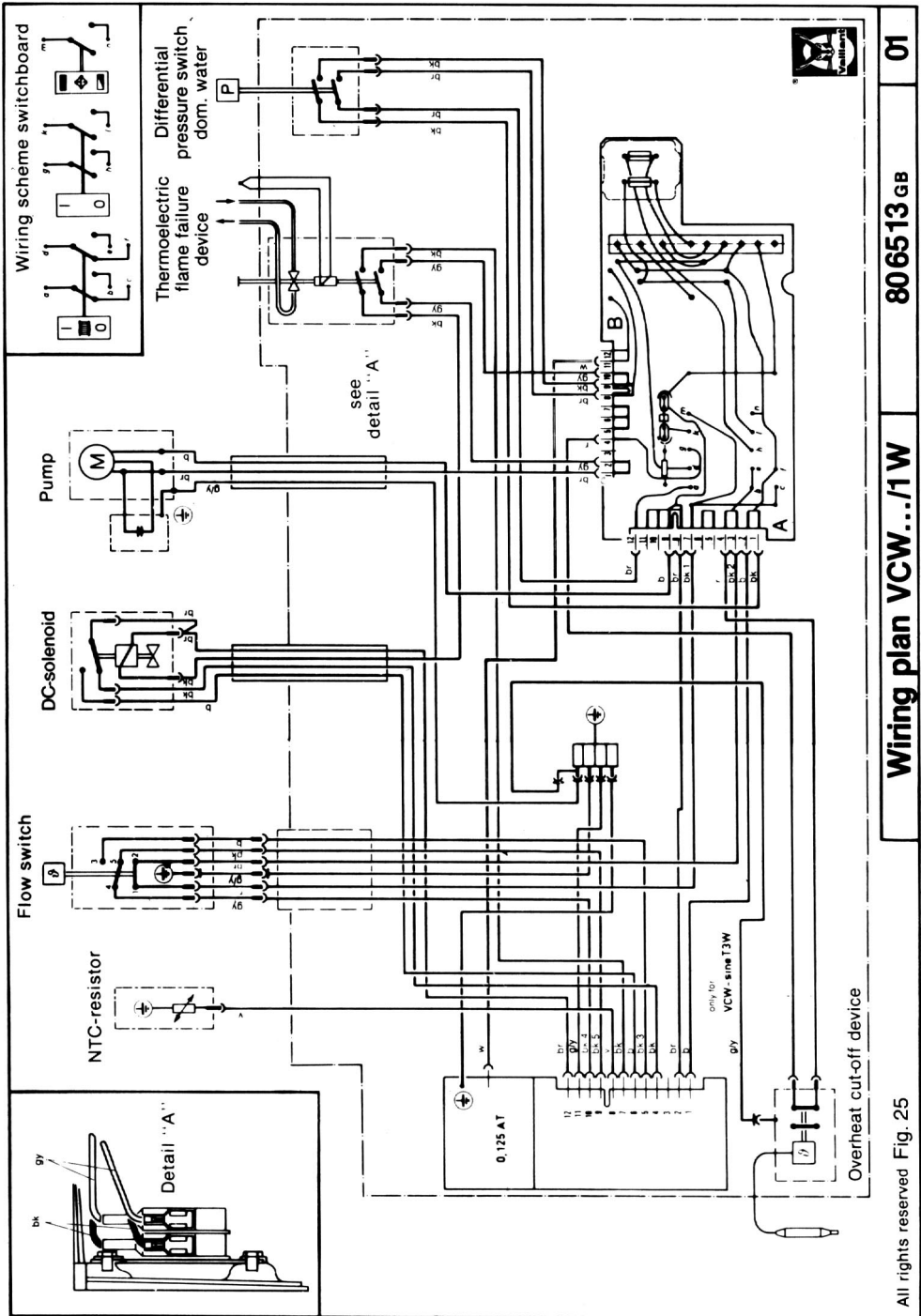

All rights reserved Fig. 25

Wiring plan VCW...11W

806513 GB

01

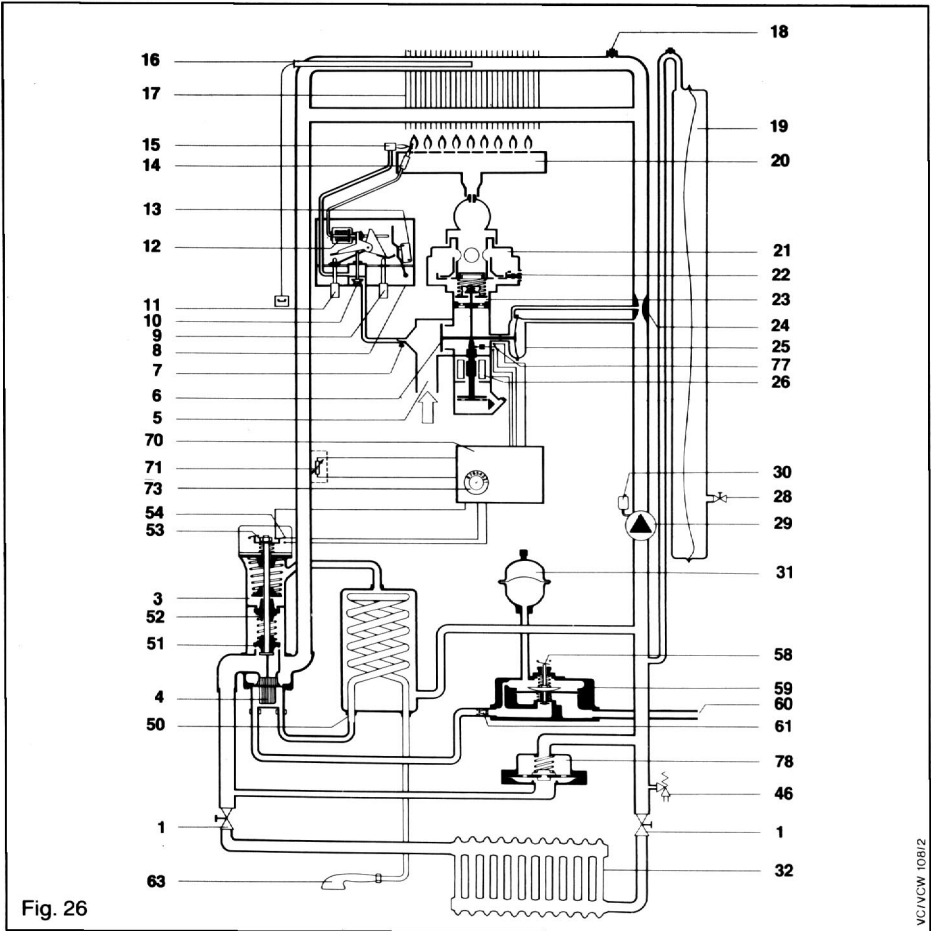

VC/MCW 10B12

Fig. 26

- | | |
|---|--|
| <ul style="list-style-type: none"> 1 service cock 3 flow switch 4 thermostatic element 5 gas inlet 6 automatic valve 7 pilot adjustment screw 8 switch box/FFD 9 push button start 10 pilot valve 11 push button stop 12 thermo-magnet 13 micro switch 14 thermo-couple 15 pilot burner | <ul style="list-style-type: none"> 16 sensor of overheat cut-off device 17 main heat exchanger 18 air venting screw 19 expansion vessel 20 main burner 21 gas governor 22 main burner adjustment screw 23 double-stage main burner valve 24 venturi 25 differential valve 26 DC solenoid 28 expansion vessel pressure control 29 pump |
|---|--|

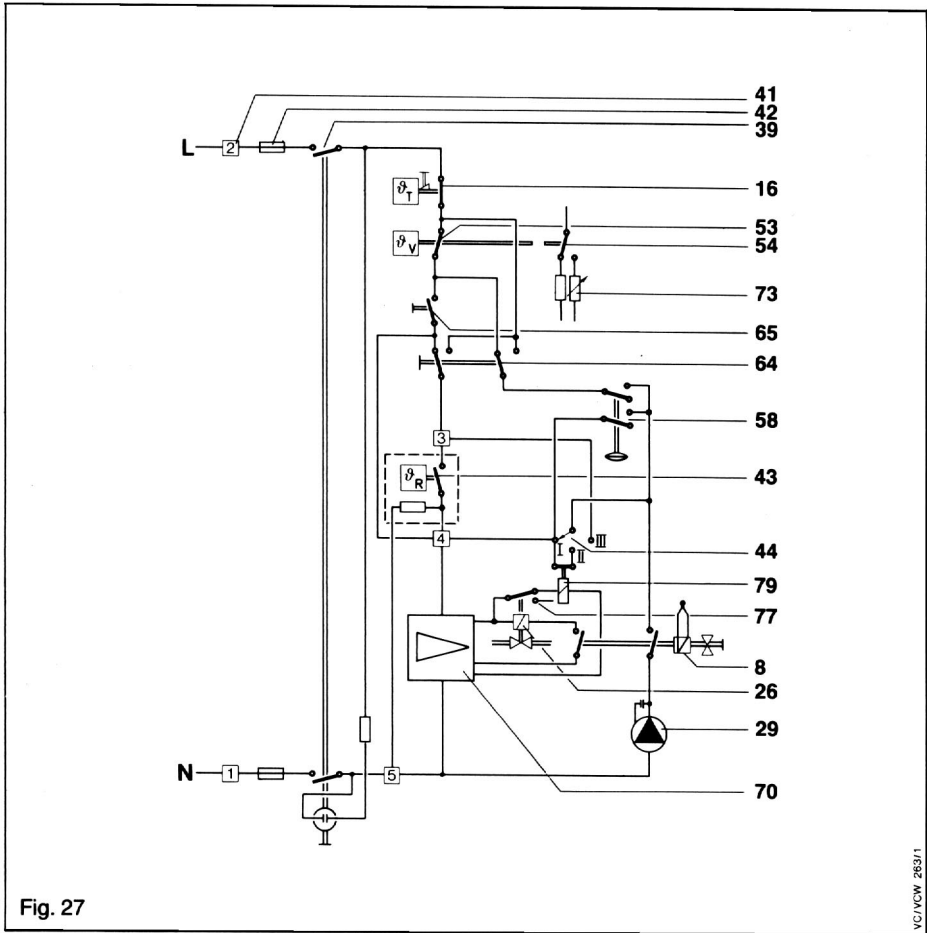

Fig. 27

VC/VOW 283/1

- 30 automatic air vent
- 31 expansion vessel domestic water
- 32 heating circuit
- 39 main switch
- 41 terminal
- 42 fuse
- 43 room thermostat
- 44 pump setting
- 46 pressure relief valve
- 50 domestic heat exchanger
- 51 heating system valve
- 52 hot water system valve
- 53 micro-switch I
- 54 micro-switch II

- 58 micro-switch hot water
- 59 water section
- 60 cold water inlet
- 61 water governor
- 63 hot water outlet
- 64 heating switch
- 65 domestic hot water switch
- 70 electronic control
- 71 NTC resistor
- 73 flow thermostat
- 77 micro-switch time control
- 78 system bypass
- 79 relay

5 Water circulating system

5.1 General

The combi boiler is suitable for use on most minibore and microbore systems.

It is recommended to use copper tubing to BS 2871 : 1 for water carrying pipework.

The use of horizontal pipe runs should be avoided wherever possible in order to prevent air collecting in the system. If horizontal runs

are unavoidable the pipes should rise upwards towards a vent point.

For general guidance reference should be made to the British Gas publication – MATERIAL AND INSTALLATION SPECIFICATIONS FOR DOMESTIC CENTRAL HEATING AND HOT WATER – B and to BS 5376 : 2 and BS 5449 : 1.

5.1.1 Single pipe system

The heat emitters are installed on a closed circuit. The necessary water quantity for every heat emitter (radiator) must be ensured. This can be done for instance by using suction fittings in the return connection of the radiators. The radiator sizes shall be calculated on the basis of temperature distribution around the circuit.

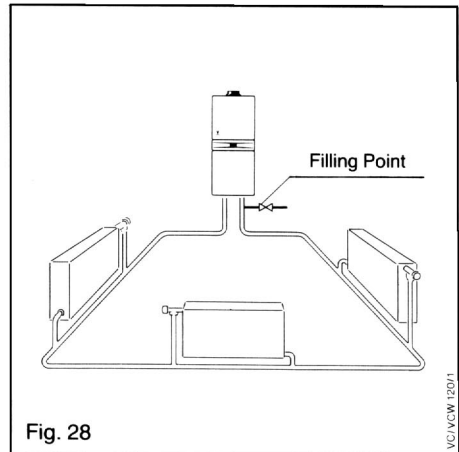

5.1.2 Two-pipe system

The radiators are installed parallel and the flow temperature therefore is the same for every radiator.

Typical central heating installations are shown in the following figures.

NOTE: 5.2 to 5.5 are applicable to both open and sealed systems.

N.B. The primary filling point may be placed at any convenient point on the circuit.

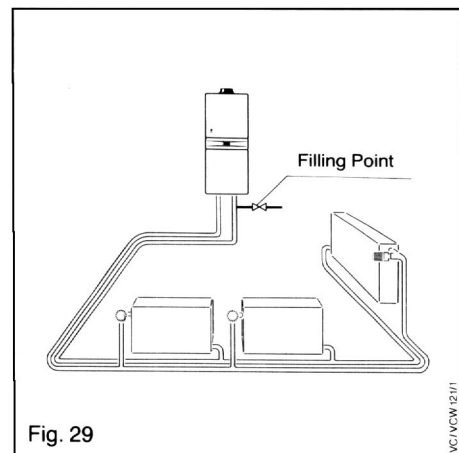

5.2 Controls

Vaillant combi boilers are ready for connecting to the electrical mains.

System controls (240 V) may be connected as shown in figures 21 to 24.

5.3 Isolating valves

The appliance shall be installed with isolating valves (service cocks) as described under 4.3.3.

5.4 Circulating pump

The circulating pump is included into the combi boiler. The remaining conveying capacity can be taken from the diagram.

5.5 System by-pass

A system by-pass is included into the combi boiler.

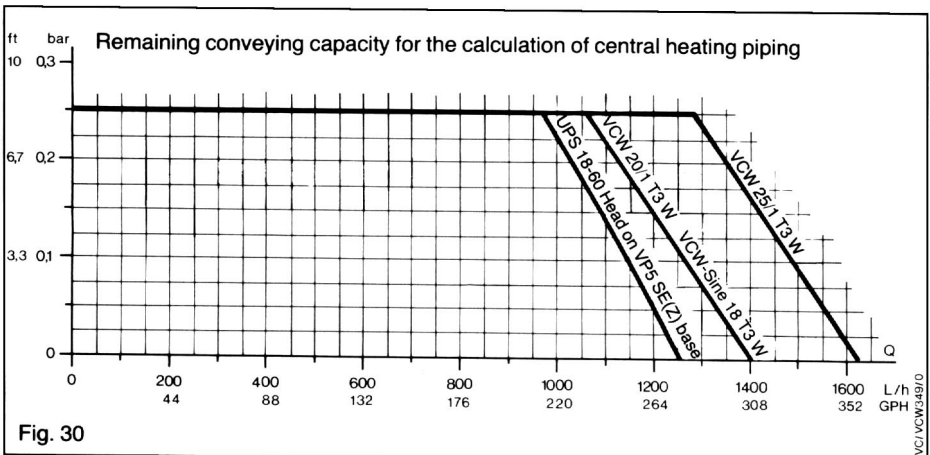

5.6 Open vented system

If it is required to use the combi heater in open systems it is possible to do so without any modification to the combi heater. We recommend to fit the expansion pipe (2) at the isolation valve (no. 7, fig. 12) where normally the pressure relief valve is fitted. The relevant British Standards and Codes of Practice as well as other requirements involved (see also 3.1) should be strictly observed.

Min static head: 0.15 bar (5' water)
 Max static head: 2.0 bar (67' water)
 see BS 5449 clause 24.1

- 2 expansion pipe
- 3 expansion cistern
- 7 overflow pipe

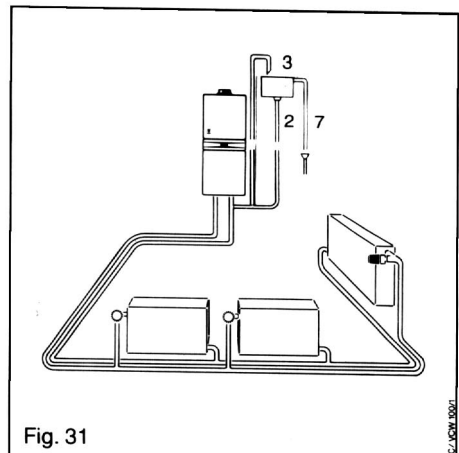

5.7 Sealed systems

Sealed systems do not require feed and expansion cisterns, open vents etc. Only good quality radiator valves and fittings should be used in order to prevent excessive detrimental topping-up.

5.7.1 Pressure relief valve

This is required on all sealed systems and is connected as shown in 4.3.4.

5.7.2 Pressure gauge

This is factory fitted to the boiler and shows the pressure in the primary circuit.

5.7.3 Expansion vessel

A 15 litres expansion vessel is incorporated into the combi boiler suitable for a sealed heating system with a maximum water contents of 260 litres (57.2 Imp. galls.).

If the nominal capacity of the built-in expansion vessel is not sufficient for the heating system (for instance in case of modernization of old open systems) an additional expansion vessel can be installed to the side connection of the return service cock in connection with the pressure relief valve.

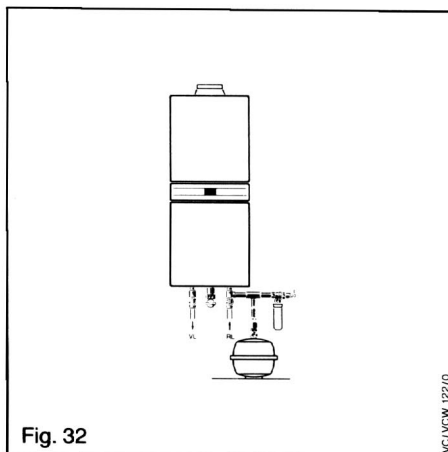

5.7.4 Filling and make up

The system should be filled with water via a separate filling point fitted at a convenient point on the heating circuit. Where local Water Authority Regulation allows, a temporary connection to the mains may be used. The connection must be removed when filling is completed. Where local Water Authority Regulation does not allow temporary connection, a sealed system filler pump with break tank must be used. **The heating system will not be filled automatically from the domestic side.**

In principle, sealed systems do not require water make-up facilities, but experience has shown that some make-up may be necessary.

Methods of filling sealed systems are given in appendix A of BS 5376 : 2.

5.7.5 Pipework

All pipework shall be securely supported, shall run neatly and be concealed where possible.

6 Commissioning and testing

6.1 Electrical installation

Preliminary electrical system checks to ensure electrical safety shall be carried out by a competent person. Those checks are outlined in the INSTRUCTIONS FOR BRITISH GAS MULTIMETER.

6.2 Gas installation

The whole of the gas installation, including the meter, should be inspected and tested for soundness and purged in accordance with the recommendations of CP 331 : 3.

6.3 Water circulation system

The whole of the system should be flushed out with both cold and hot water. Ensure all valves are open.

With the combi boiler fitted, the system should be filled and air locks cleared. Vent the boiler through the 4 vent points shown in fig. 1 and 2. Loosen the black cap on the automatic air vent by 1–2 turns. Vent all heat emitters and check for water soundness. On a sealed system fill until the pressure gauge registers 1.5 bar (21.5 PSI).

(The system should be filled with water either from a sealed system filler pump with a break tank or by a method of filling given in BS 5376 : 2, appendix A.)

Check operation of safety valve. Release water from the system until the initial system pressure of 1,2 bar is attained, taking into account any difference in height between the pressure gauge and the point at which the highest heat emitter is connected.

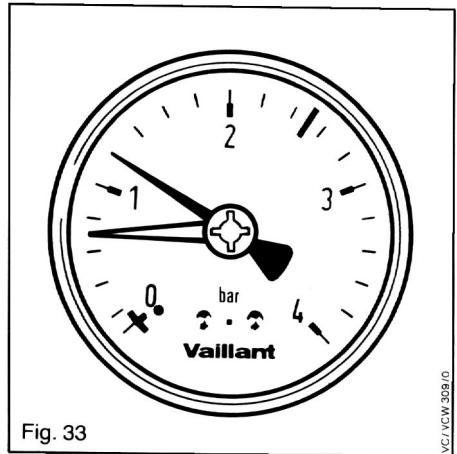

6.4 Lighting the combi boiler

The first lighting of the appliance shall be done by a qualified fitter only. He shall also give clear verbal instructions to the user on how to operate the combi boiler, controls and systems generally. Light the combi boiler as described separately in the "Instructions for use".

6.4.1 Gas soundness

Test for gas soundness around boiler gas components using sense of smell and leak detection fluid.

6.4.2 Main burner pressure

Pull off the plug of the NTC-resistor and test the main burner pressure at the main burner pressure test point.

6.4.2.1 Nominal heating input

The pressure must be as follows:

inlet pressure: 20 mbar (8.08 in. WG)

main burner pressure (cold and hot):

VCW 20/1 9.0 mbar (3.61 in. WG)

VCW 25/1 9.0 mbar (3.61 in. WG)

VCW-sine 18 10.6 mbar (4.26 in. WG)

The appliance is regulated at factory to the nominal heating input. Therefore it is not necessary to alter the setting of input or output at the gas governor during installation.

- 1 pilot adjustment screw
- 2 pilot gas filter
- 3 DC solenoid
- 4 main burner pressure test point
- 5 gas governor
- 6 blocking plate
- 7 inlet pressure test point (near rear plate)

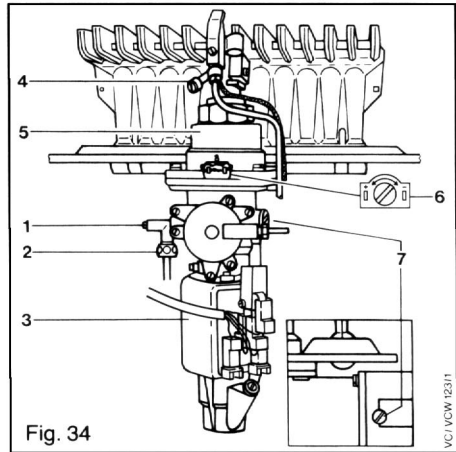

6.4.3 Flue

Check that there is no spillage of products of combustion from the down draught diverter by carrying a spillage test as detailed in BS 5440 : 1. (Applicable only to open-flued appliances.) Check appearance of flames in order to establish that there is adequate air for combustion, check also as outlined under 3.5.3 if there is any type of extract fan fitted.

6.4.4 Flame failure device

Check the operation of the flame failure device on the combi boiler to ensure that the device will shut off gas to the main burner within 60 seconds.

6.4.5 Flow thermostat

Check the flow thermostat and all automatic controls are operating satisfactorily. Readjust controls to appropriate settings.

6.5 Water soundness

Allow the water system to reach maximum working temperature and examine for water soundness. The system should then be turned off and rapidly drained while still hot. The water system should again be filled and cleared of air locks. Sealed systems should be adjusted to the initial system design pressure of 1,2 bar. Examine for water soundness.

6.6 User's instructions

Hand the instructions for use to the user for retention and instruct in the safe operation of the appliance. Advise the user of the precautions necessary to prevent damage to the system and to the building if the system does not remain operative during frost conditions.

Note: Leave installation and servicing instructions at the meter.

For continued efficient and safe operation, your Vaillant appliance should be serviced at least once a year by a qualified servicing company.

It is important and strongly recommended that arrangements are made for a Maintenance Agreement with a qualified servicing company to ensure regular servicing.

Please contact your servicing company, your nearest Vaillant office or your local gas region.

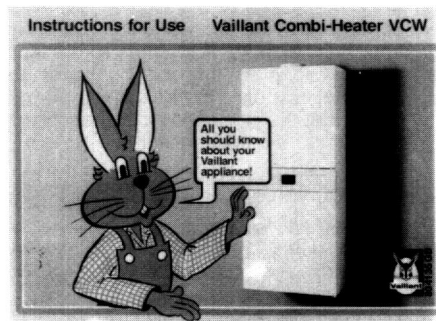
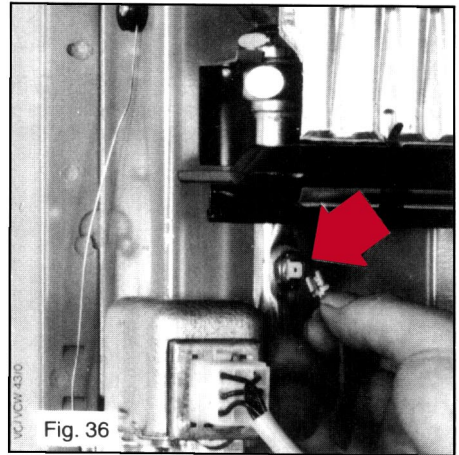

Fig. 35

7 Assembling

Replace the plug to the NTC (Negative Temperature Coefficient) resistor before assembling.



7.1 Lint arrester (open flued appliance)

To fit the lint arrester hang it into the front side of the lower retaining frame and clip it against the appliance.

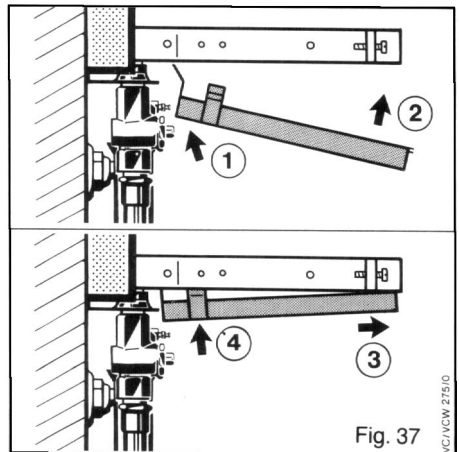

7.2 Side panels

Push the 2 side panels from the front onto the boiler and screw to the upper and lower frames with two pairs of captive slotted screws. If the door is required to open from the right see section 7.6.

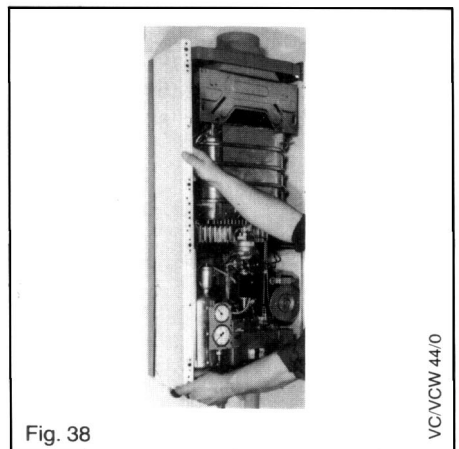

7.3 Screen plate

Position the left hand edge of the screen plate under the side panel. Press the slide under the edge of the right hand side panel and align with the slots in the screen plate. Secure the screen plate with 3 screws as indicated in fig. 39. Replace the thermostat knob.

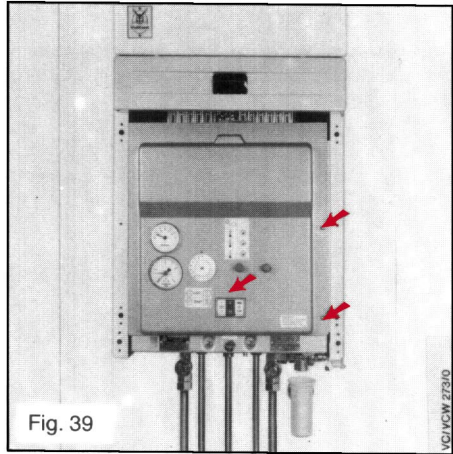

Fig. 39

7.4 Front panel

Press the front panel including the grey enameled centre section onto the boiler, the 4 bolts engage in the spring-bolted supports.

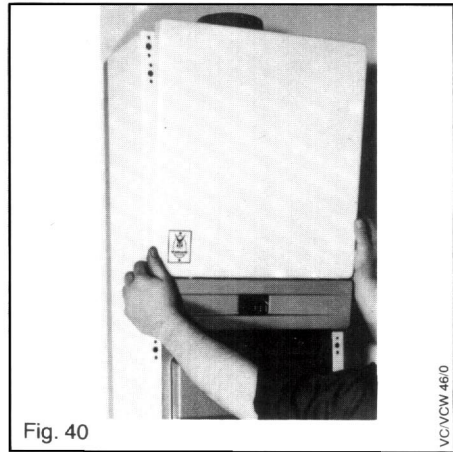

Fig. 40

7.5 Door

The door supports are attached at the right hand side panel of the appliance (door opening from the left). The door is fitted as follows: place the door into the upper support and fix to lower support with the hinge screw.

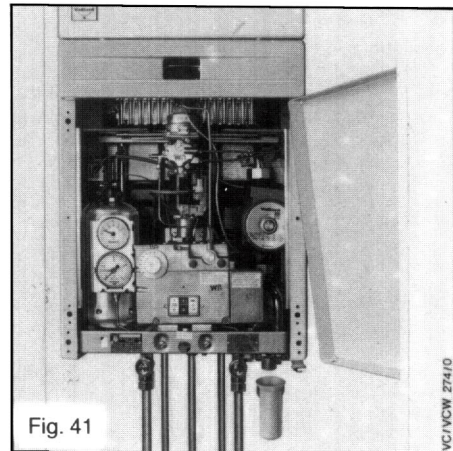

Fig. 41

7.6 Changing door attachment

The door can also be fitted to open from the right, as described in the following: Change the upper and the lower door support from the right hand to the left hand side panel of the appliance.

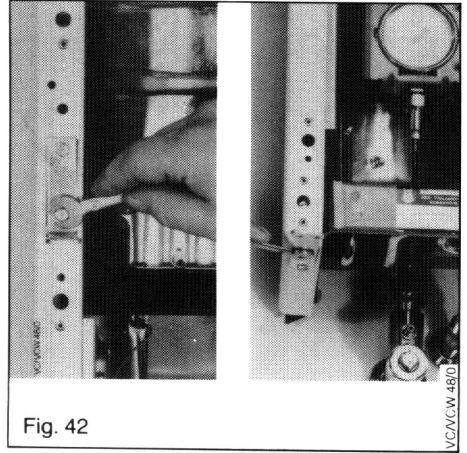

Fig. 42

7.7 Stickers

Stick on

- instructions sheet after filling in
 - serial no.,
 - test point pressure and
 - date of commissioning
- wiring diagram

to the inner side of the door as shown on fig. 43.

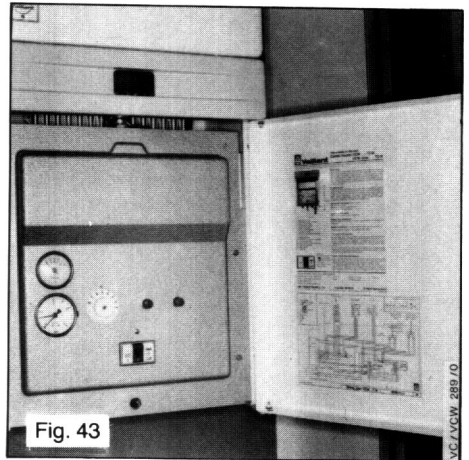

Fig. 43

8. Servicing of combi boiler

The combi boiler should be serviced at least once a year. A service contract may be agreed with BRITISH GAS or your CORGI INSTALLER.

8.1 Turning off the combi boiler

To service the combi boiler

- Switch off electrical supply (1, fig. 44).
- Turn off gas service cock (3, fig. 44), boiler isolating valves (4, fig. 44) and cold water shut-off valve (5, fig. 44).

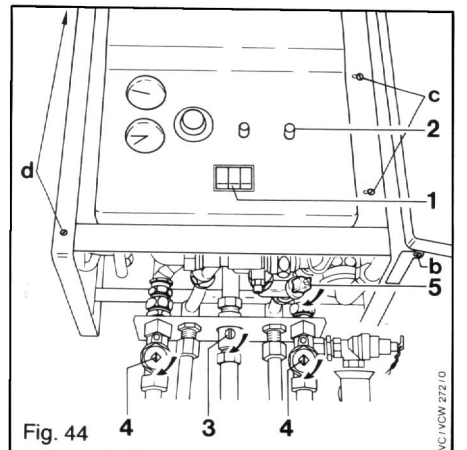
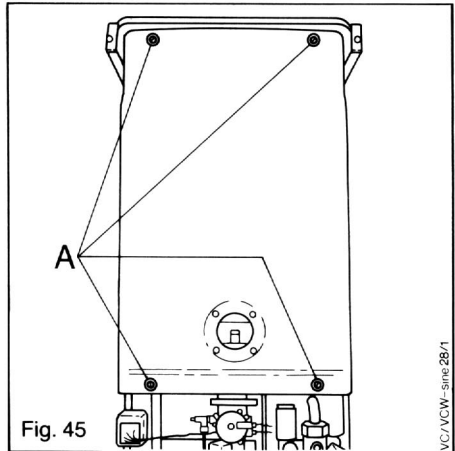

Fig. 44

8.1.1 Removing outer case (fig. 44)

Remove door by unscrewing hinge pin (b) and pulling door out and down. Remove upper panel by pulling outwards. Remove gauge panel by removing boiler thermostat knob, screw over rocker switches and loosening screws (c) and sliding right hand panel to the left.

Remove side panels by unscrewing top and bottom screws (d) to clear internal clips and then pulling panels outwards and off. In the case of the balanced flued combi boiler VCW-sine remove the 4 screws and washers (A) to remove combustion chamber case as shown in fig. 45.



8.1.2 Draining the appliance (fig. 44 and 46)

When necessary, the appliance may be drained as follows.

- Open air vent (18, fig. 46).
- Drain appliance through drain nipple (B, fig. 46).
- Drain domestic heat exchanger via drain screw (C, fig. 46) as well as pressure relief valve (D, fig. 46) at the lower part of the water section.

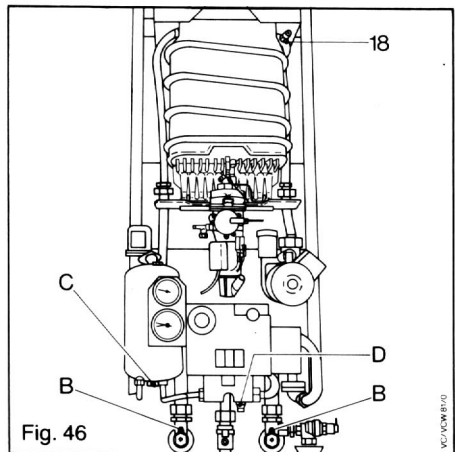

8.2 Cleaning of burner and lint arrestor

8.2.1 Cleaning of burner

8.2.1.1 Balanced flued appliances

Remove the burner by unscrewing the retaining union nut (E), the pilot air filter (F), take care not to lose the pilot injector. Remove the thermo couple by pulling down and taking off the high tension lead from the ignition electrode.

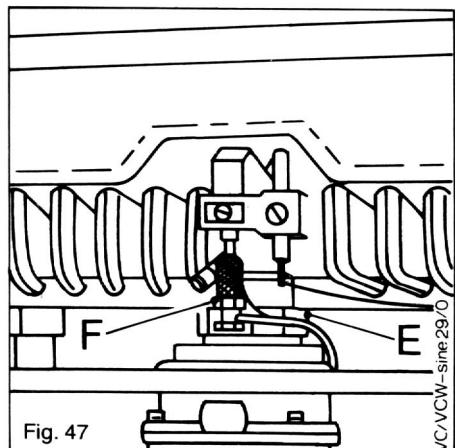

Unscrew the retaining screws (T) and remove burners. Clean burners, injectors nozzles and pilot assembly with a light brush or a vacuum cleaner.

Reassemble in reverse order, replacing the main burner gasket if necessary.

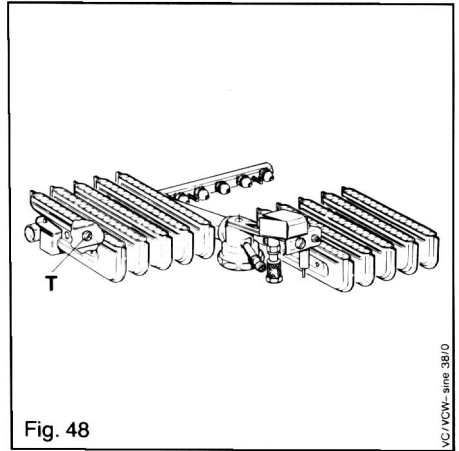

8.2.1.2 Open flued appliance

Remove burners by levering off burner bar with a screwdriver. Remove thermo-couple probe by pulling downwards from pilot assembly so that probe disengaged from circlip. Remove pilot assembly by unscrewing screw (F).

Remove burner bar by unscrewing nut (E).

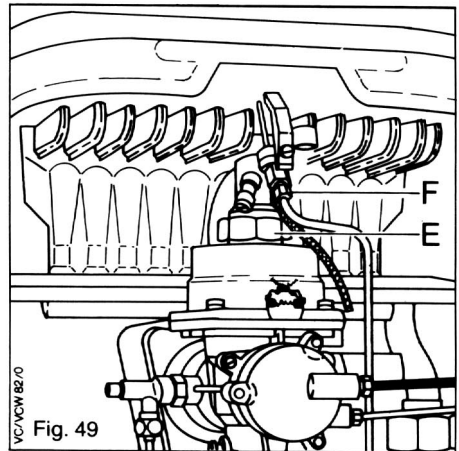

Clean burners and injectors with a light brush or vacuum cleaner. Reassemble in reverse order, replacing main burner gasket if necessary.

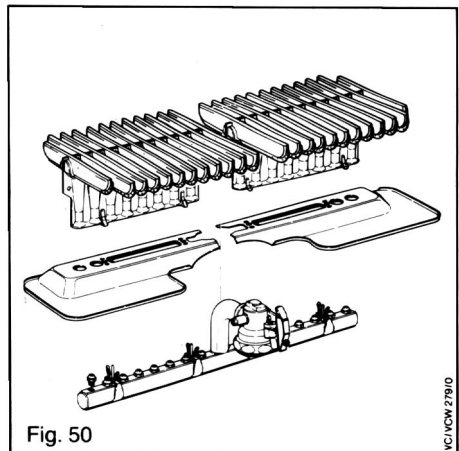

8.2.2 Cleaning of lint arrester (open flued appliances)

Remove the lint arrester by pulling downward the part which is near the connections of the appliance.

Clean with the light brush or a vacuum cleaner. Reassemble in reverse order.

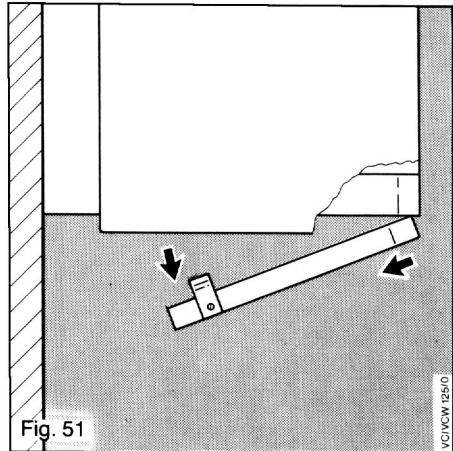

8.3 Cleaning of main heat exchanger

8.3.1 Balanced flued appliances

Remove burner as under 8.2.1.1. Slacken the 2 screws holding the flue hood and slide hood up as far as possible.

Remove sensor (3) of overhear cut-off device from pocket on left hand side of heat exchanger. Undo union nuts (G) on heat exchanger unions and slacken locking nuts (H) above them. Remove heat exchanger.

Clean heating body especially fins carefully with hot water, detergents and brush. If necessary descale with propriety descaling agent. Do not bend the fins. If necessary, straighten carefully with screwdriver.

8.3.2 Open flued appliance

Remove burner assembly as under 8.2.1.2. Slacken split collar.

Slacken the 2 screws holding the draught diverter and slide draught diverter up as far as possible. Remove sensor (3) of the overhear cut-off device from the pocket on left hand side of the heat exchanger. Undo union nuts (G) on the heat exchanger unions and slacking locking nuts (H) above them. Remove heat exchanger, clean heating body and especially fins carefully with hot water, detergent and brush. If necessary, descale with proprietary descaling agent. Do not bend the fins, if necessary straighten carefully with screwdriver.

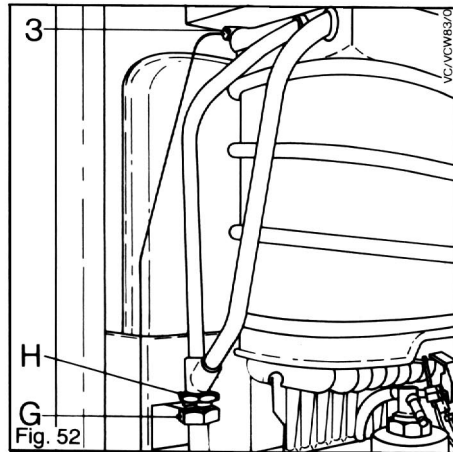

Remove the venturi tube situated in the right-hand connection of the heating body. Check bore and o-ring, clean bore and replace o-ring, if necessary.

Reassemble in reverse order, ensuring washers are fitted in heat exchanger unions and flue duct engaged in spigot in flue terminal.

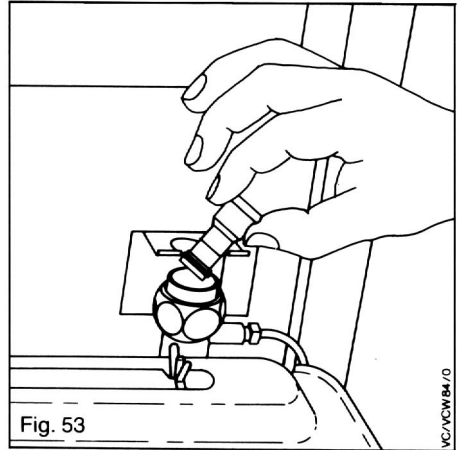

8.4 Descaling of domestic heat exchanger

When necessary to descale the domestic heat exchanger remove the tube connecting the pressure gauge and the heating system by unscrewing the 2 tubing nuts. For better access to the connections remove the lower retaining frame by unscrewing the 5 retaining screws. Remove the 3 union nuts (K) and the 2 retaining screws (I). Descal the domestic water tubes by proprietary descaling agents and rinse afterwards with clean water.

Reassemble in reverse order using new washers.

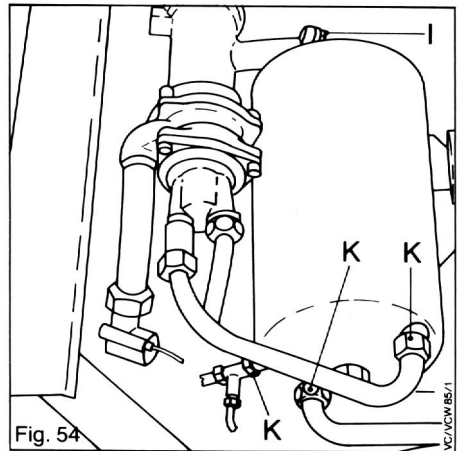

8.5 Cleaning of water section

To remove the water section unscrew the internal (N) and the external (M) water connections and loosen the screw (L).

For better access to the connections unscrew the lower retaining frame.

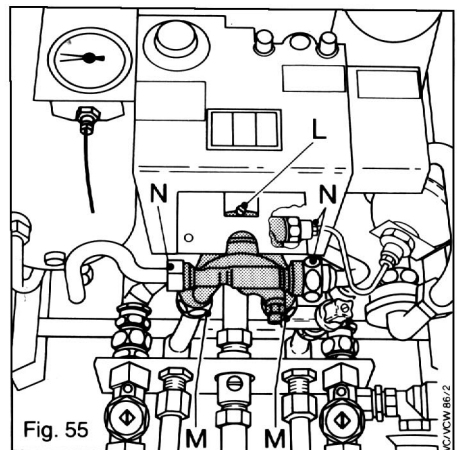

Open the water section. Clean the water filter (O) or replace, if necessary. Check diaphragm (P) and water governor (61), replace, if necessary.

Reassemble in reverse order using new washers.

Where stuffing gland needs replacing fit new top to water section, incorporating new stuffing box.

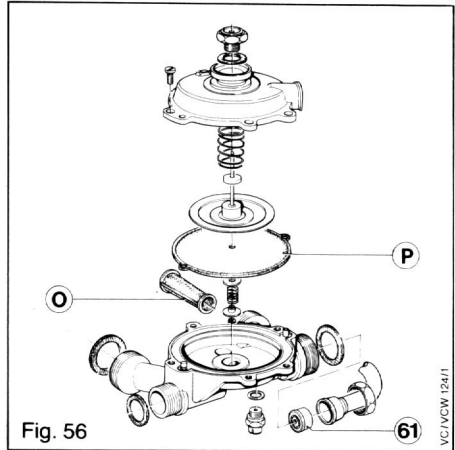

8.6 Maintenance of differential valve

Mark and disconnect the two unions and unscrew the three retaining screws (Q).

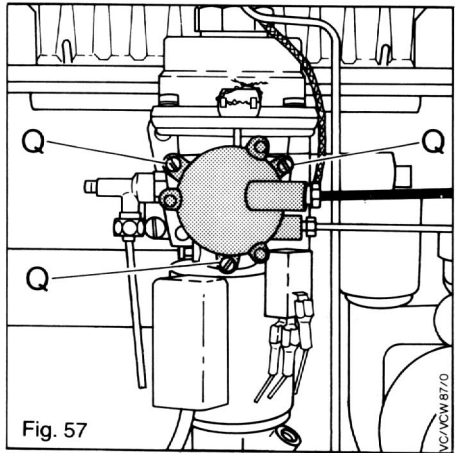

Open differential valve and clean. Check diaphragm and replace, if necessary. Check easy running pin of diaphragm disc in stuffing box. In case of replacement of the stuffing box, it is recommendable to replace also diaphragm disc. Lubricate pin with suitable grease.

Mark and disconnect the two control lines and clean by blowing through.

Reassemble in reverse order.

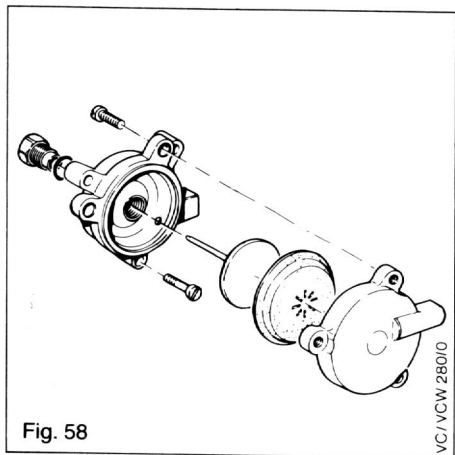

8.7 Expansion vessel (sealed heating system only)

Check internal pressure of expansion vessel which should be 0,7 to 0,9 bar, if heating system of appliance is without pressure (black dial of built-in pressure gauge at 0). Refill with air pump, if necessary.

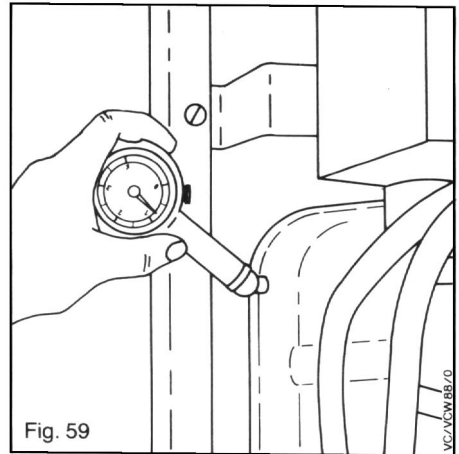

8.8 Final tests

8.8.1 Final test heating system

Close all drain screws and nipples and open the service cocks to refill the appliance. If a sealed system ensure the pressure is 1.2 bar according to 6.3. Switch on electricity, turn on gas and start the appliance as outlined on the sticker at the inner side of the front door. Check flame failure device for correct functioning. Check the pilot flame and adjust with the pilot rate adjuster (7) so that there are three separate flames. If the flame profile is one large, loose flame, increase gas rate until 3 separate flames develop, as shown in fig. 60a. Replace pilot jet if necessary.

Check the appliance for soundness.

Check all controls for correct functioning, reassemble outer casing of appliance as under 7.

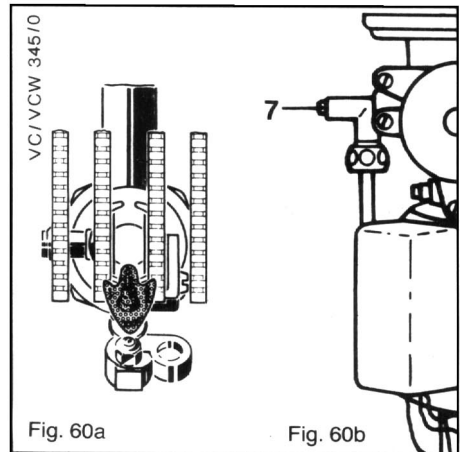

8.8.2 Final test electrical system

- Check – earth continuity
- polarity
- resistance to earth

according to INSTRUCTIONS FOR BRITISH GAS MULTIMETER.

8.9 Change of pilot jet

Disconnect the pilot tube from the pilot. Change pilot jet and washer and reassemble in reverse order.

In case of an open-flued appliance remove the pilot assembly by unscrewing the retaining screw. Change the pilot jet and reassemble in reverse order.

Check connections for gas soundness.

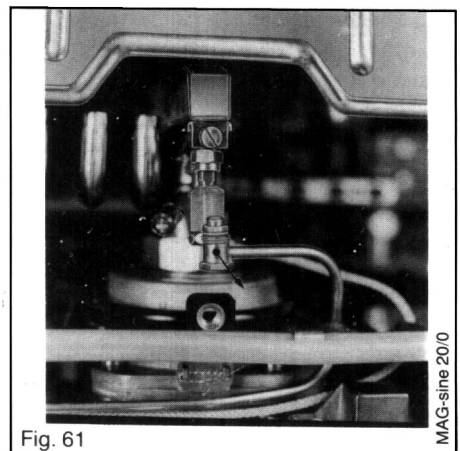

8.10 Change of thermocouple

Disconnect the retaining nut (R) and pull the thermocouple out of the thermocouple support. Insert the new thermocouple fully into the support. (In case of VCW-sine seal the thermolead into the bottom of the chamber plate by a special rubber washer). Connect the retaining nut.

8.11 Change of spark electrode (VCW-sine only)

Pull off the high voltage lead, remove the retaining screw (S), remove the spark electrode and replace with the new electrode. Reassemble in reverse order, ensuring that the spark gap from the electrode to the flame shield is 3 mm, taking care not to overtighten the fixing screw.

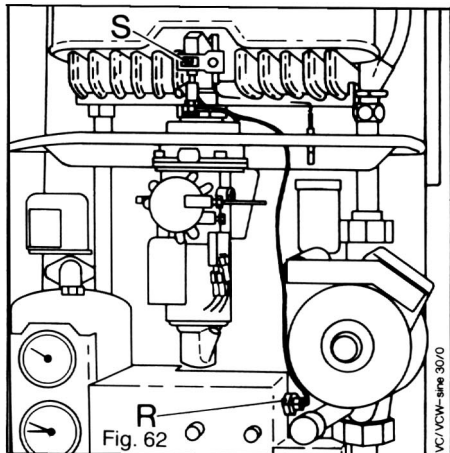

8.12 Change of NTC (negative temperature coefficient) probe

Disconnect the AMP plug and unscrew the NTC probe. Reassemble in reverse order.

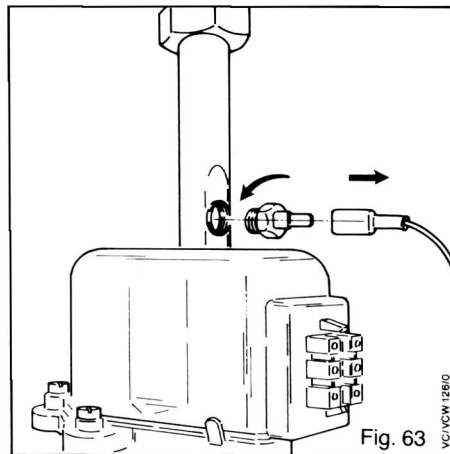

8.13 Change of automatic air vent

Drain the appliance as under 8.1 and 8.1.2. Unscrew the automatic air vent by hand. Reassemble in reverse order, screwing the automatic air vent in by hand only. Open the locking cap (LC) of the automatic air vent by 1–2 turns.

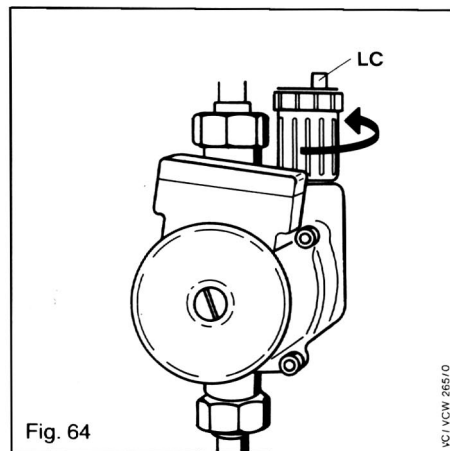

8.14 Change of flow switch or parts

8.14.1 Electrical isolation

Isolate the appliance from the electrical mains. Pull off the plug (S1) by shifting the retaining tongues (S2) top and bottom to the side.

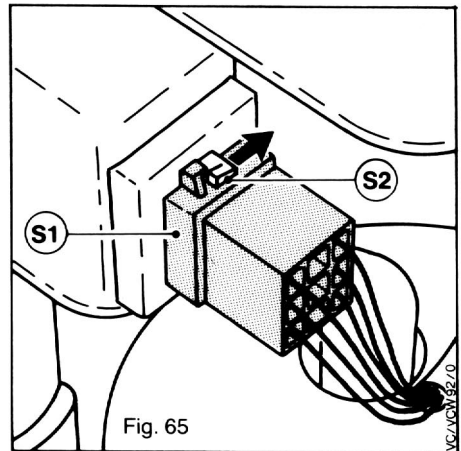

8.14.1.1 Change of flow switch micro switches

Spring off the protective cover (S6). Unscrew (S7) or (S8), take off micro switch and remove the AMP plugs.

Reassemble in reverse order.

Adjust the actuating lever as outlined under 8.14.2.1.

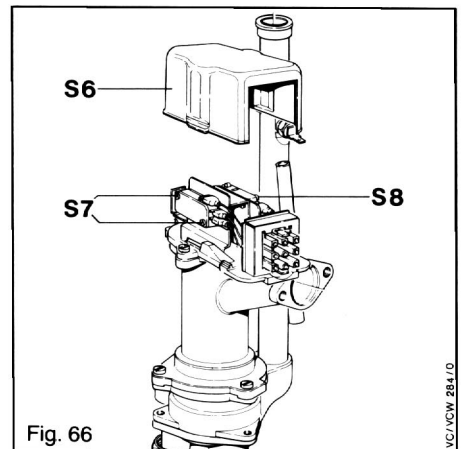

8.14.2 Removal of complete flow switch

Drain the appliance as under 8.1 and 8.1.2.

Remove the 4 unions (S3) and the 2 screws (S4). Pull off the AMP tag (S5) of the NTC resistor.

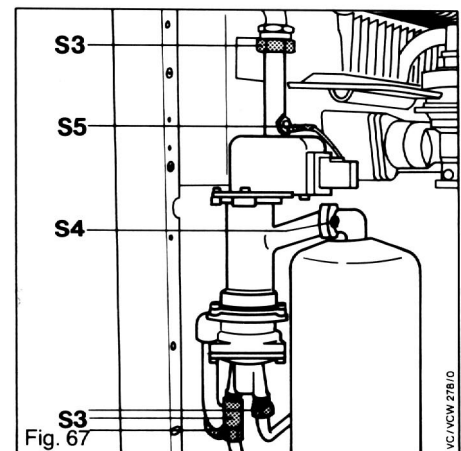

8.14.2.1 Change of flow switch stuffing box

Remove complete flow switch as in 8.14.2. Unscrew retaining screw (S9) and take off the micro switch assembly. Unscrew adjustment nut (S10), remove lever assembly, remove 3 screws securing top cover, unscrew stuffing box, remove both rubber seals and fit new seals, ensuring washer is fitted between the seals. Reassemble in reverse order and adjust lever assembly of the cold flow switch as follows: Turn down the adjustment nut (S10) slowly until micro switch closes the red to brown circuit and make one more complete turn down.

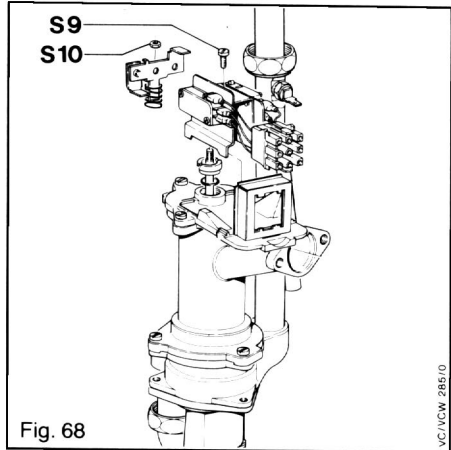

8.14.2.2 Change of thermostatic element

Unscrew the 3 retaining screws (S11) and remove the housing (S12). Reassemble in reverse order, using new washers.

8.14.2.3 Changing internal seals

Remove housing as in 8.14.2.2.

Remove seals R1 and R2 and replace with new ones. Do not use any jointing compound or grease.

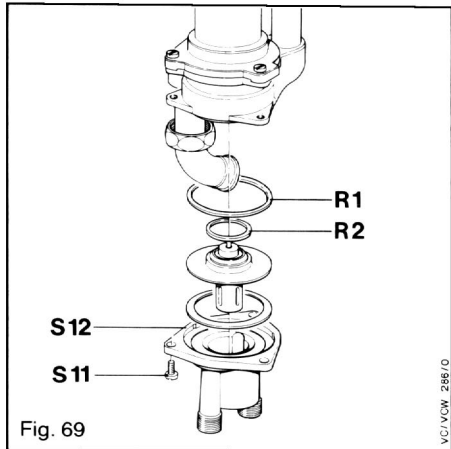

8.14.3 Reassembling

Reassemble in reverse order, using new washers.

- Check
- earth continuity
 - polarity
 - resistance to earth

according to INSTRUCTIONS FOR BRITISH GAS MULTIMETER.

Note: position of notches on plug as shown.

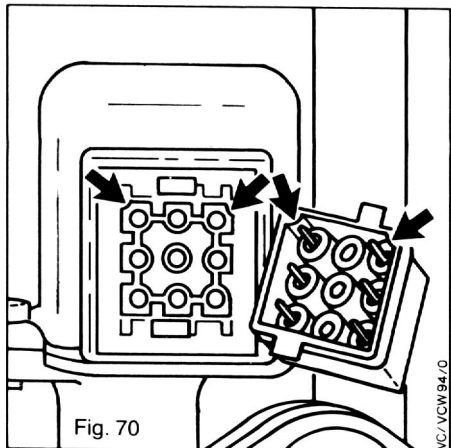

8.15 Change of piezo igniter (VCW-sine only)

Disconnect the high voltage lead (P1) from the duct bolt. Remove the retaining screw (P2) and remove the unit by springing the bracket. Reassemble in reverse order, ensuring that locating dimple in the bracket aligns with the slot in the piezo unit.

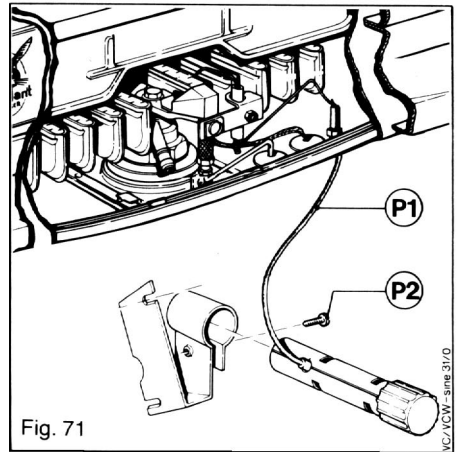

8.16 Change of DC solenoid

Isolate the appliance from the electrical mains. Note colour code and pull off the AMP plugs (D1) from the micro switch as well as the AMP plugs (D2) from the DC solenoid socket. Loosen the 2 retaining screws (D3). Reassemble in reverse order.

Check – earth continuity
– polarity
– resistance to earth

according to INSTRUCTIONS FOR BRITISH GAS MULTIMETER.

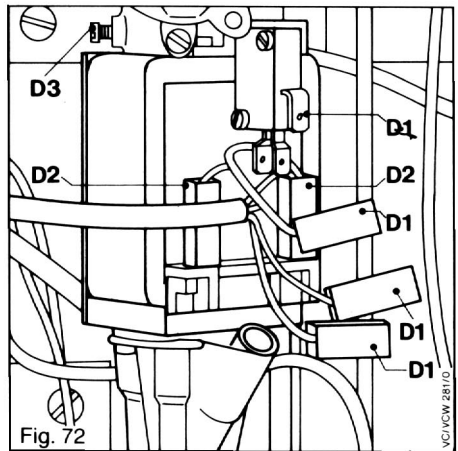

8.17 Change of DC solenoid micro switch

Isolate the appliance from the electrical mains. Note the colour code and pull off the AMP plugs (M1). Unscrew the 2 retaining screws (M2). Reassemble in reverse order.

Check – earth continuity
– polarity
– resistance to earth

according to INSTRUCTIONS FOR BRITISH GAS MULTIMETER.

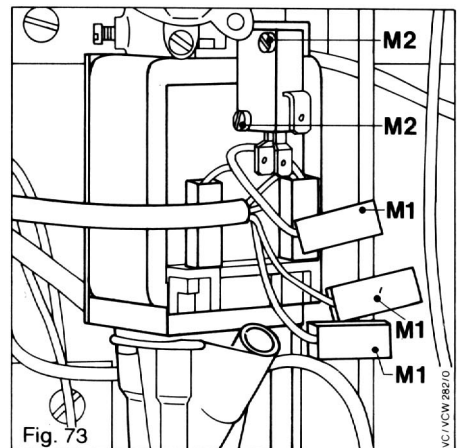

8.18 Change of pump

8.18.1 Change of complete pump

Drain the appliance as under 8.1 and 8.1.2.

Isolate the appliance from the electrical mains. Open the terminal box of the pump. Note the colour code of wiring and disconnect pump connection cable.

Unscrew the automatic air vent (P1) by hand. Mark and disconnect the 2 control lines of the automatic valve by unscrewing the tubing nuts (P2). Loosen the 2 pump unions (P3) and unscrew the bracket fixing screw (P4) and the union nut (P5) at the right hand connection to the main heat exchanger.

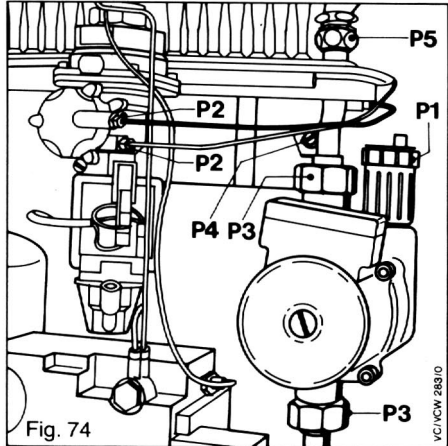

8.18.1.1 Open flued boiler

Take off connection to main heat exchanger together with the pump as shown on fig. 75. Reassemble in reverse order, using new washer at the right hand connection to the main heat exchanger.

Screw in the automatic air vent by hand only.

- Check – earth continuity
- polarity
- resistance to earth

according to INSTRUCTIONS FOR BRITISH GAS MULTIMETER.

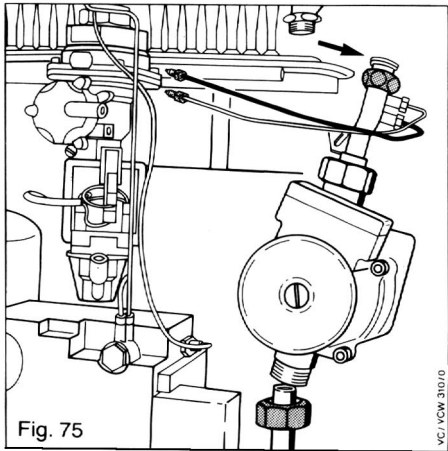

8.18.1.2 Balanced flued boiler

Unscrew the upper pump union (P3) and spring off the pump as shown in fig. 76. Reassemble in reverse order, using new washer at the right hand connection to the main heat exchanger.

Screw in the automatic air vent by hand only.

- Check – earth continuity
- polarity
- resistance to earth

according to INSTRUCTIONS FOR BRITISH GAS MULTIMETER.

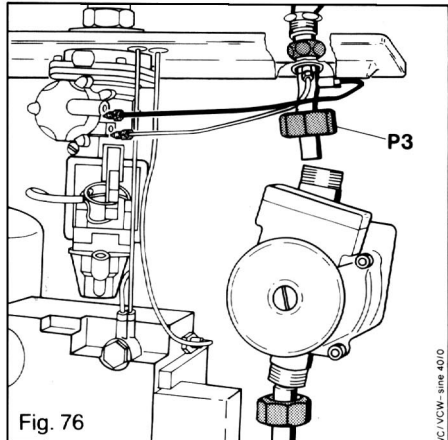

8.18.2 Change of pump head only

Drain the appliance as under 8.1 and 8.1.2.

Isolate the appliance from the electrical mains. Open the terminal box of the pump. Note the colour code of the wiring and disconnect the pump connection cable. Unscrew the 4 retaining screws (P6) and pull off pump head. Replace with Vaillant Grundfos type VP5SE(Z) resp. VP6SE(Z) or Grundfos UPS 18-60. Reassemble in reverse order. Take care not to damage the packing ring.

- Check
- earth continuity
 - polarity
 - resistance to earth

according INSTRUCTIONS FOR BRITISH GAS MULTIMETER.

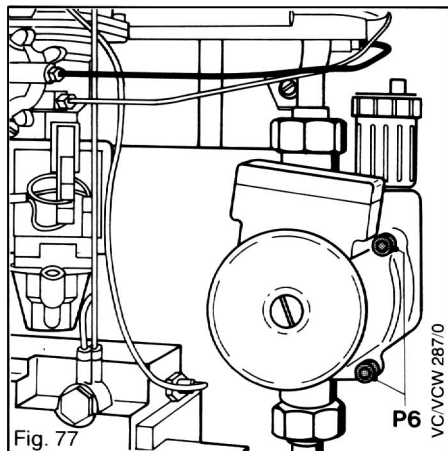

8.19 Change of gas section

Disconnect the differential valve as under 8.6. Control lines remains connected. Remove pilot gas line from the pilot gas filter by disconnecting the union nut (G1). Remove DC solenoid by loosening the 2 retaining screws (G2).

8.19.1 Balanced flued appliance

Remove thermo-couple from pilot assembly and remove burner assembly.

8.19.2 Open flued appliance

Remove the pilot support by unscrewing the retaining screw (G3) and the main burner assembly. Remove the 4 retaining screws (G4), replace valve seating, springs etc. as necessary. Reassemble in reverse order, using new gaskets.

Check connections for gas soundness.

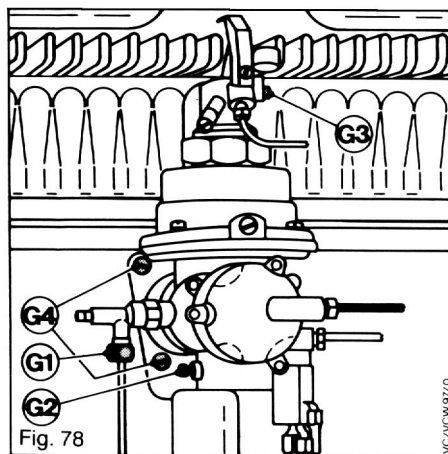

8.20 Change of gas governor

8.20.1 Balanced flued appliance

Remove gas section as in 8.19 and 8.19.1. Unscrew the 4 retaining screws (G5). Reassemble in reverse order, using new washers, if necessary. Check connections for gas soundness.

8.20.2 Open flued appliance

Remove the main burner as under 8.2.1.2. Unscrew the retaining screws (G5), reassemble in reverse order, using new washers, if necessary.

Check connections for gas soundness.

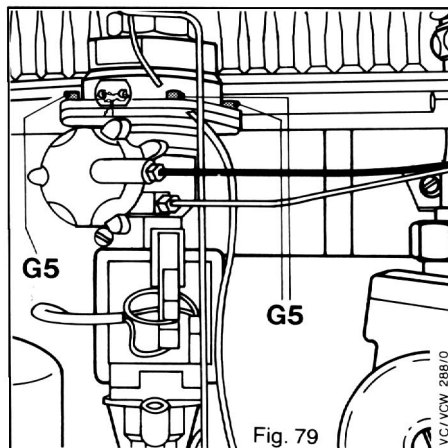

8.21 Change of pilot gas filter

Remove pilot gas line from the pilot gas filter by disconnecting the union nut (G6). Unscrew the pilot gas filter from the gas section.

Reassemble in reverse order, using suitable sealing compound sparingly.

Check connections for gas soundness.

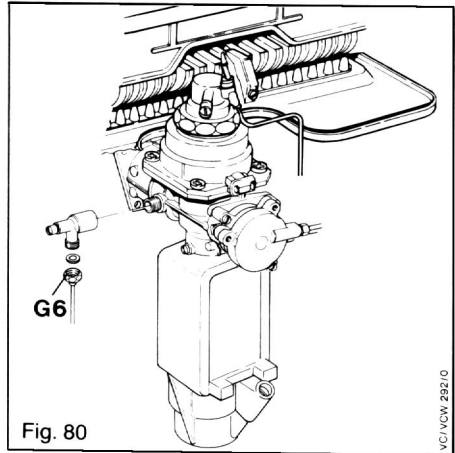

Fig. 80

VC/NCW 292/0

8.22 Change of automatic valve stuffing box

Disconnect the differential valve as under 8.6. Control lines remain connected. Unscrew the stuffing box (G7), taking care not to bend the pin. Reassemble in reverse order, using new washer.

Check connections for gas soundness.

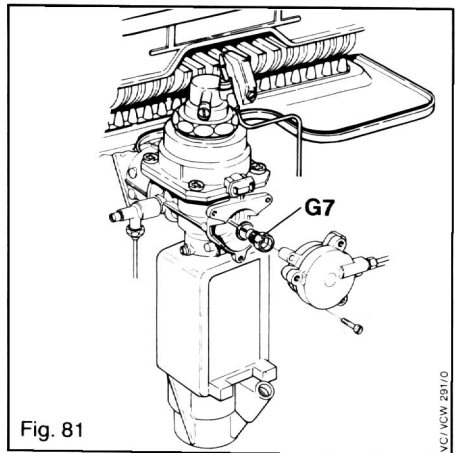

Fig. 81

VC/NCW 291/0

8.23 Change of switch box

Isolate the appliance from the electrical mains. Mark the pilot lines, disconnect the tubing nuts and remove pilot lines.

Pull the thermocouple out of the pilot burner assembly and unscrew the retaining union nut (B2) from the switch box.

Remove the 2 retaining screws (B1) and pull out the switch box. Note the colour codes of the wiring and pull the AMP plugs from the micro switches.

Reassemble in reverse order.

- Check – earth continuity
- polarity
- resistance to earth

according to INSTRUCTIONS FOR BRITISH GAS MULTIMETER.

Check connections for gas soundness.

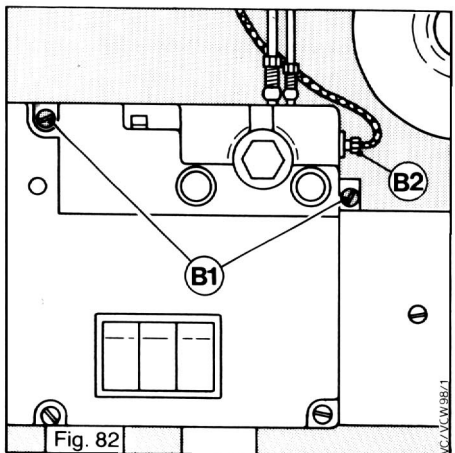

Fig. 82

VC/NCW 985/1

8.24 Change of FFD valve stuffing box

Remove the switch box as outlined in 8.23 and the thermo-magnet as outlined under 8.27.

Unscrew the stuffing box (B2) and replace by a new one, using new washer.

Reassemble in reverse order.

- Check
- earth continuity
 - polarity
 - resistance to earth

according to INSTRUCTIONS FOR BRITISH GAS MULTIMETER.

Check connections for gas soundness.

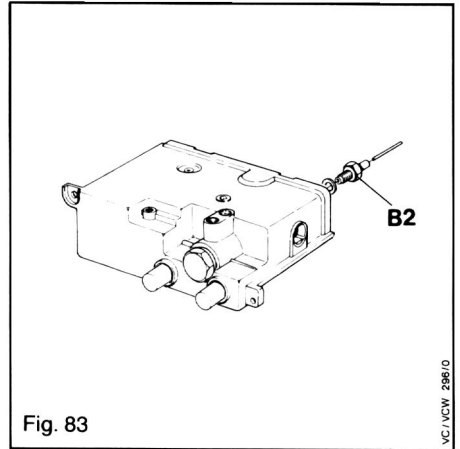

Fig. 83

VC/VCW 286/0

8.25 Change of FFD push buttons

Remove the switch box as outlined under 8.23.

Remove locking ring (B3) and pull out the push button to the front.

Reassemble in reverse order.

- Check
- earth continuity
 - polarity
 - resistance to earth

according to INSTRUCTIONS FOR BRITISH GAS MULTIMETER.

Check connections for gas soundness.

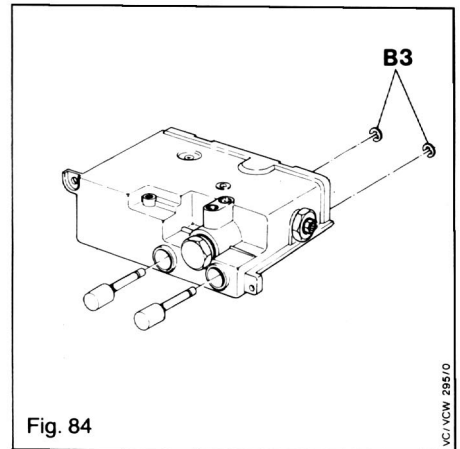

Fig. 84

VC/VCW 285/0

8.26 Change of pilot valve

Unscrew the plug (B4) and pull out spring (B5) and valve (B6) to the front, taking care not to bend the valve pin (B7). Reassemble in reverse order, using a new washer.

Check connections for gas soundness.

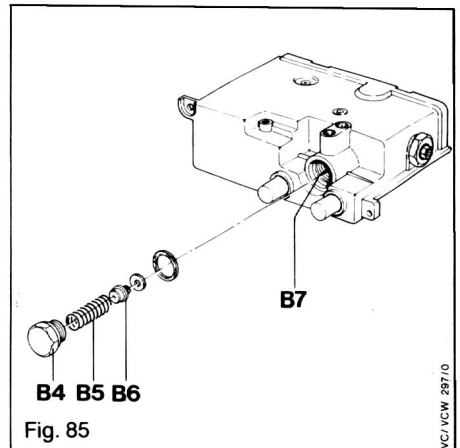

Fig. 85

VC/VCW 287/0

8.27 Change of thermo-magnet

Remove the switch box as outlined under 8.23.

Remove micro-switch assembly by unscrewing the 2 retaining screws (B8). Straighten tap washer (B9), unscrew retaining nut (B10), pull out thermo-magnet (B11) carefully. Re-assemble in reverse order.

- Check – earth continuity
– polarity
– resistance to earth

according to INSTRUCTIONS FOR BRITISH GAS MULTIMETER.

Check connections for gas soundness.

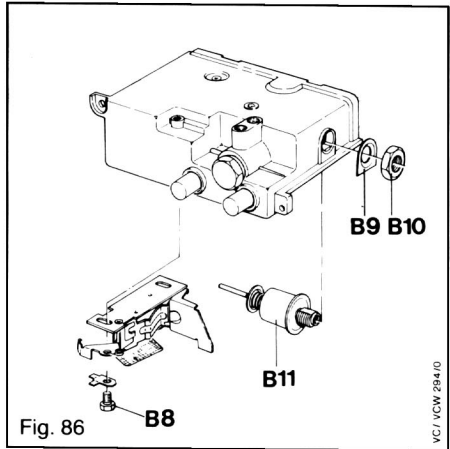

8.28 To open the control box

Isolate the appliance from the electrical mains. Open the main terminal box by removing the retaining screw (C1). Remove the four retaining screws (C2).

Lift up the switch board and pull out slowly the control box cover complete with the switch board, printed circuit and terminal board. Pull off the multiple plugs from the printed circuit. Reassemble the box in reverse order. When replacing the screws, position the 2 star washers diagonally to the screws.

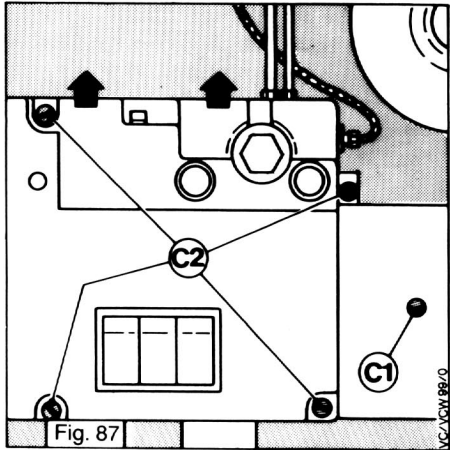

8.29 Change of main switch board

Take off the switch board as outlined under 8.28. Disconnect the mains cable from the terminals. Unscrew the 2 retaining screws (C3) and remove the p.c.b. with the main switch from the control box cover.

Reassemble in reverse order.

- Check – earth continuity
– polarity
– resistance to earth

according to INSTRUCTIONS FOR BRITISH GAS MULTIMETER.

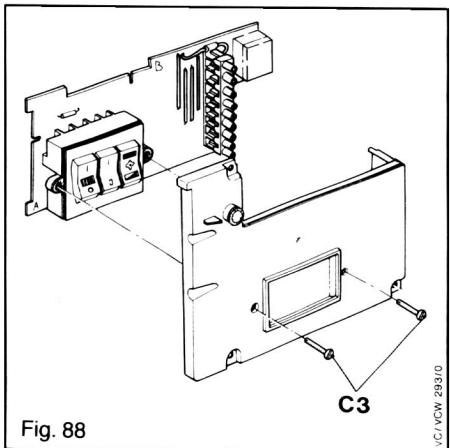

8.30 Change of micro-switches of water section

Open control box as in 8.28 and remove switch box as in 8.23. Remove the adjustment screw (C5) and take off the microswitch assembly. Pull off AMP plugs (C4).

Reassemble in reverse order.

- Check – earth continuity
- polarity
- resistance to earth

according to INSTRUCTIONS FOR BRITISH GAS MULTIMETER.

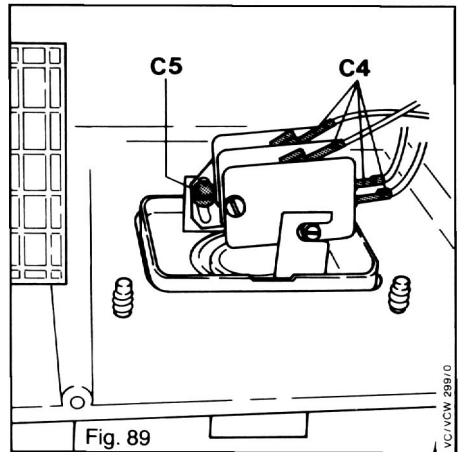

8.31 Change of overheat cut-off device

Open the control box as in 8.28 and remove the switch box as in 8.23.

Pull off the 2 plugs (C6) and the earth lead, remove the saddle clip (C7), pull the sensor (3, fig. 52) out of the main heat exchanger. Unscrew the 2 retaining screws (C8), release grommet from box and remove cut-off device.

Reassemble in reverse order.

- Check – earth continuity
- polarity
- resistance to earth

according to INSTRUCTIONS FOR BRITISH GAS MULTIMETER.

Check connections for gas soundness.

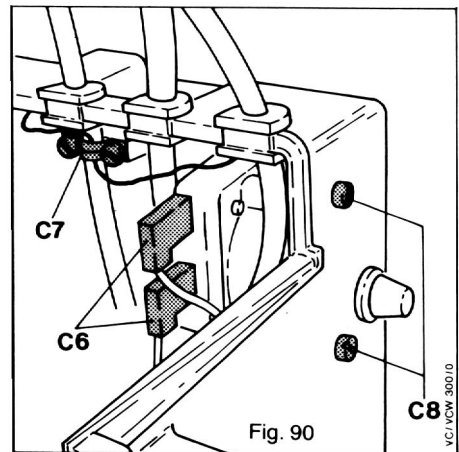

8.32 Change of electronic p.c.b.

Open the control box as outlined under 8.28. Unscrew the retaining screw (C9) on the left hand side of the control box. P.c.b. is held on key-hole slot, pull p.c.b. forward and to the right. Pull off multiplug and white lead.

Reassemble in reverse order and ensure the p.c.b. is located on the left hand side of plastic peg.

- Check – earth continuity
- polarity
- resistance to earth

according to INSTRUCTIONS FOR BRITISH GAS MULTIMETER.

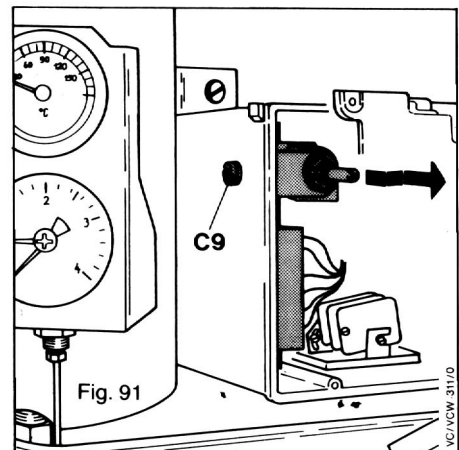

8.33 Change of expansion vessel

8.33.1 Domestic water side

Disconnect the tubing nut (W1), unscrew bracket securing screw and remove expansion vessel complete with bracket. Unscrew vessel from bracket. Reassemble with new domestic water expansion vessel in reverse order.

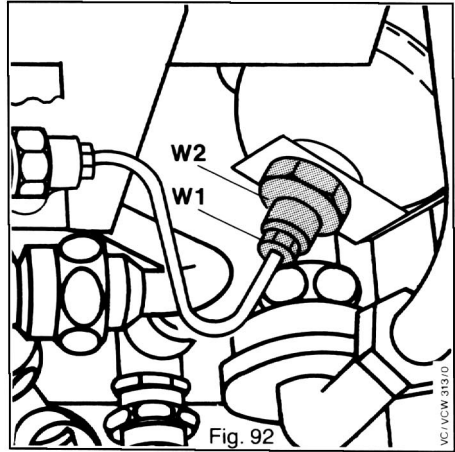

8.33.2 Heating system open flued appliances

Disconnect the flue at split collar. Remove 2 screws and nuts, securing the upper retaining frame. Lift rear of frame clear of side frames and rest it on top of draught diverter. Remove screws securing draught diverter and remove together with upper retaining frame. Remove draught diverter retaining frame by removing the 2 retaining screws. Undo the union nut (W3), move the expansion vessel up and take it off. Reassemble in reverse order, taking care that the expansion vessel is correctly fixed into the 2 supports. Use new washer, if necessary.

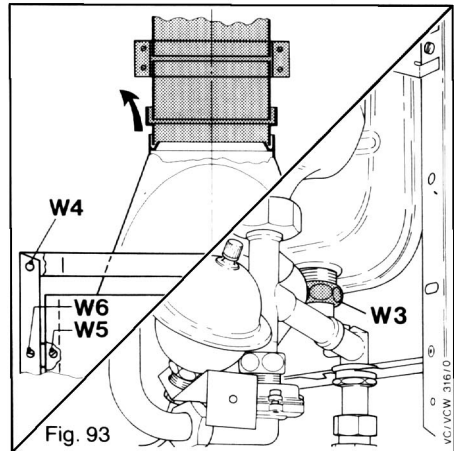

8.33.3 Heating system balanced flued appliance

Isolate electrical mains and remove mains cable. Close off water and gas service cocks and drain the appliance as outlined in 8.1.2.

Disconnect flow and return connections at compression joints on top of service cock. Disconnect gas connection at compression joint on top of gas cock. Disconnect domestic hot and cold connections on diaphragm body. Slacken locking nuts on flow and return connections. Remove nuts from bolts (1 in fig. 14) on terminal/duct assembly. Remove boiler from wall. Disconnect sleeve nut (W3) and remove expansion vessel. Reassemble in reverse order, taking care that the expansion vessel is correctly fixed to the 2 supports.

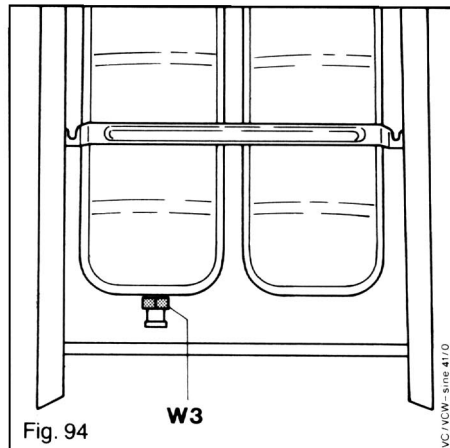

8.34 Change of thermometer

Pull the temperature sensor (U3) out of the sensor tube. Press the 2 tongues into the thermometer and pull it out to the front side.

Reassemble in reverse order.

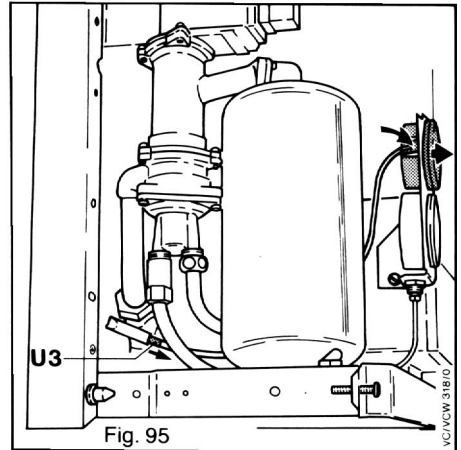

8.35 Change of manometer

Disconnect the tubing nut (U1) of the control line and remove the fixing nut (U2).

Reassemble in reverse order.

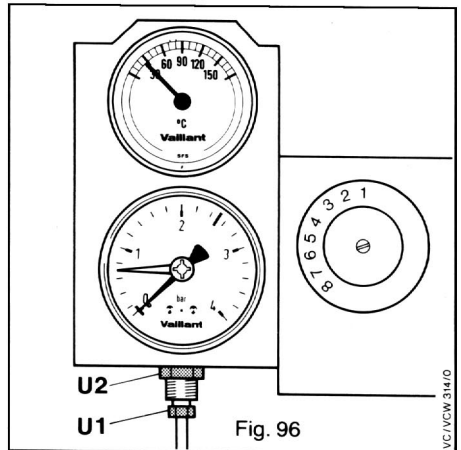

8.36 Change of system bypass

Close off flow and return service cocks and drain boiler as outlined in 8.1.2.

Unscrew the 2 union nuts (V) and remove valve. Unscrew the 3 screws holding the top of the valve. Renew diaphragm or spring as necessary. Do not move spring adjusting nut. Reassemble in reverse order, using new washers.

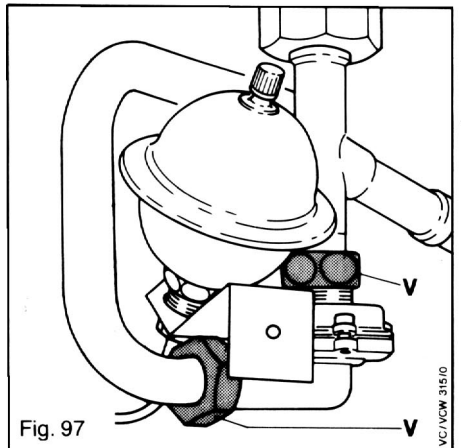

9 Fault Finding

9.1 Sheet 1: Check of Flame Failure Device and Thermocouple

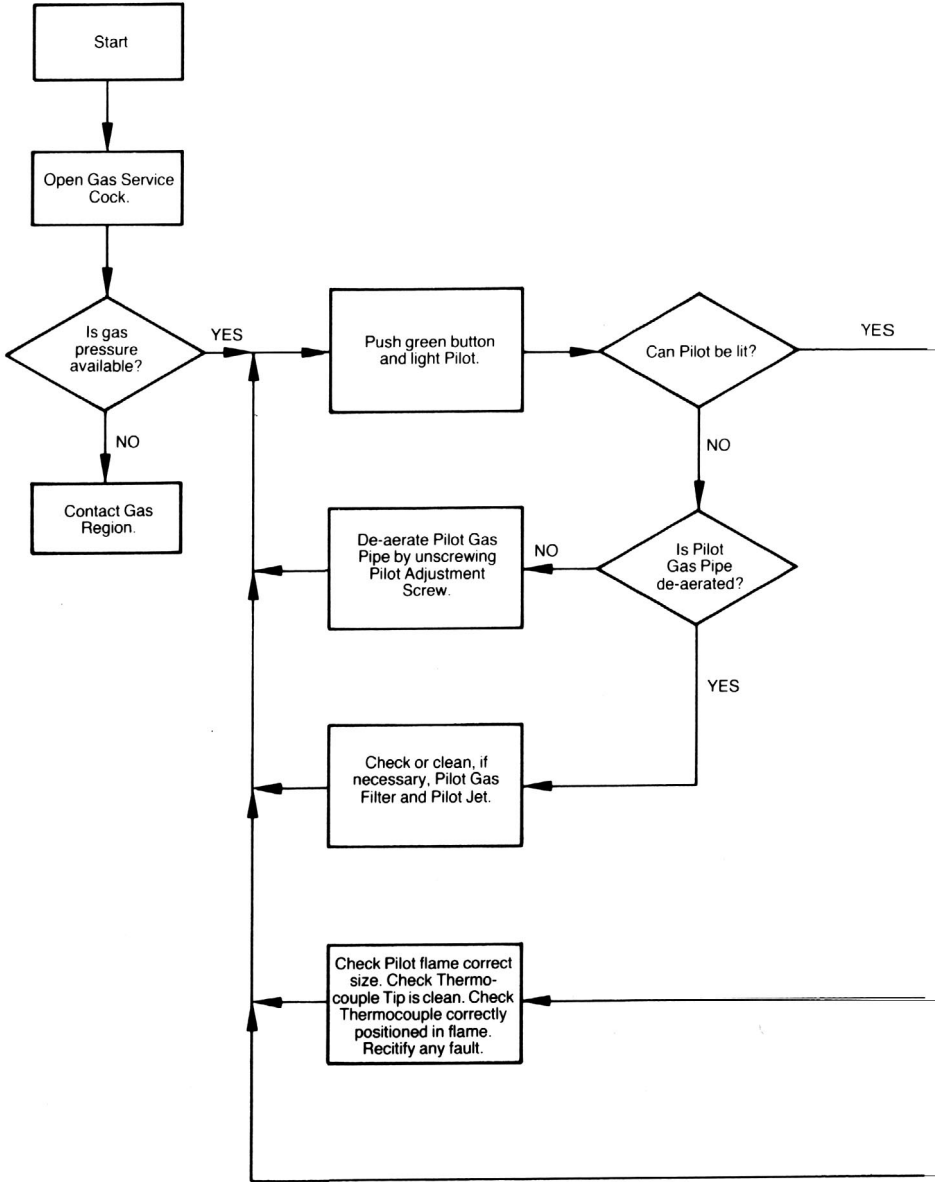

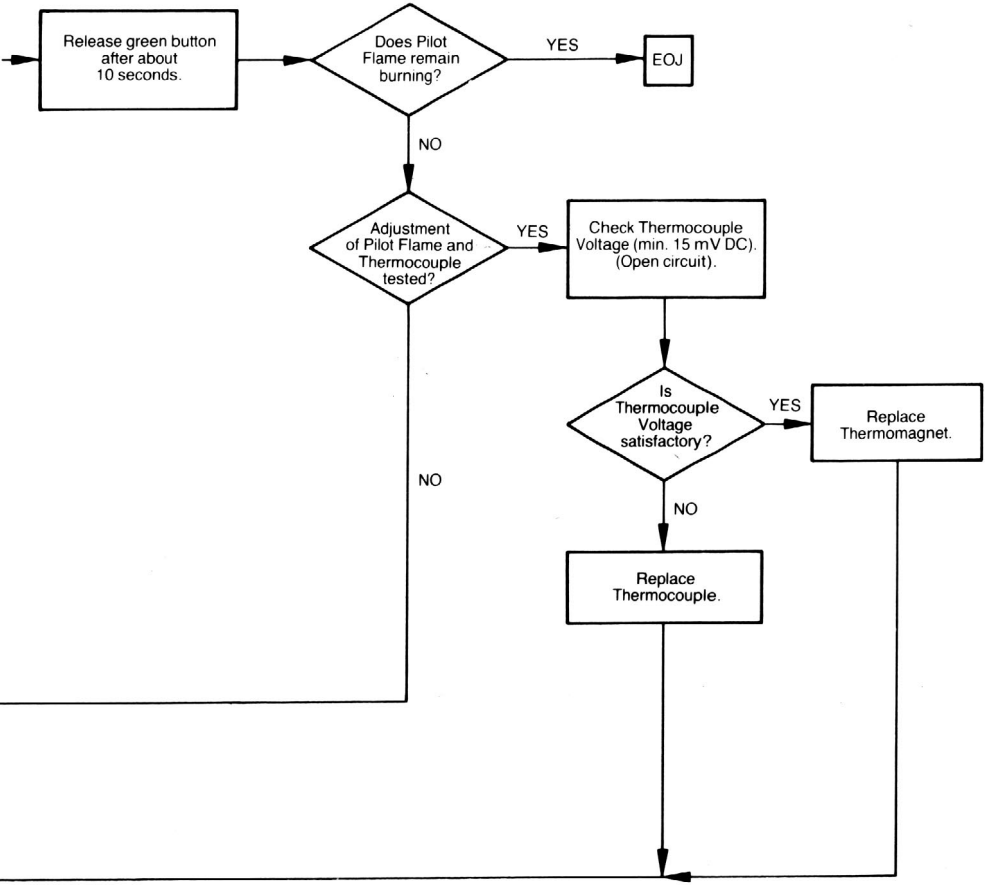

9.2 Sheet 2: Check Electricity Supply

IMPORTANT: The preliminary Electrical System Checks as contained in the B.G.C. multimeter instruction book are the first electrical checks to be carried out during a fault finding procedure. On completion of the service/fault finding task which has required the breaking and remaking of electrical connections then the checks – A. Earth Continuity, C. Polarity and D. Resistance to Earth – must be repeated.

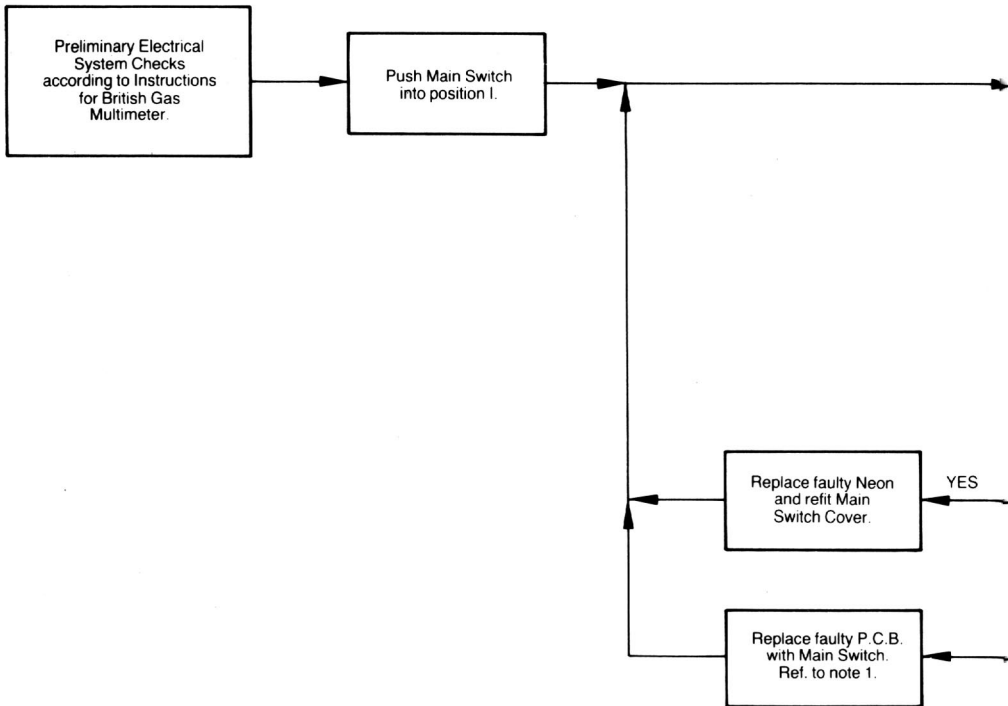

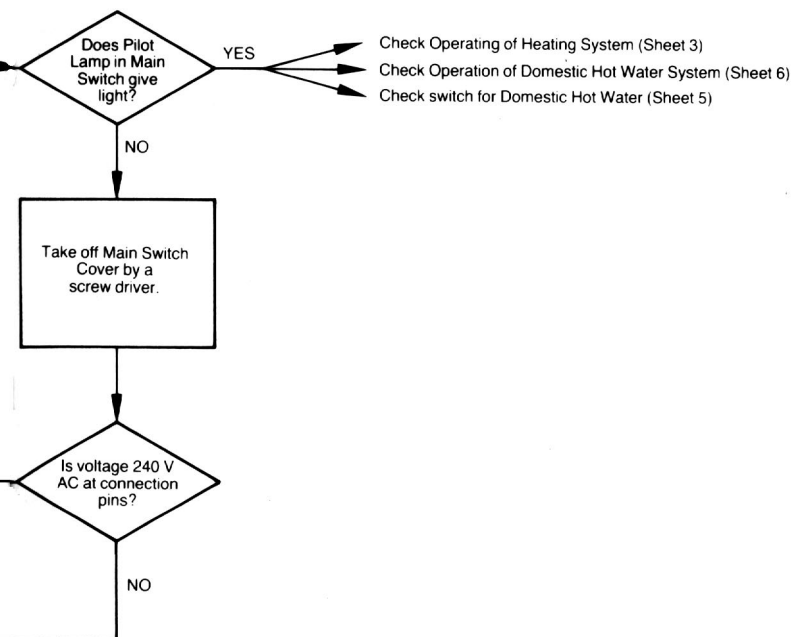

- Note 1: Detach the following parts of the control box:
- unscrew the cover of the terminal box
 - unscrew upper part of control box (2 screws) and press it a little bit upwards
 - unscrew knob of boiler thermostat
 - unscrew front panel of control box with switch group
 - pull off multicontact plugs A and B
 - remove printed circuit by loosening the two screws beside the switch group
 - install new printed circuit

9.3. Sheet 3: Check Operation of Heating System

(Do not use domestic hot Water, switch for domestic hot water remains in Position )

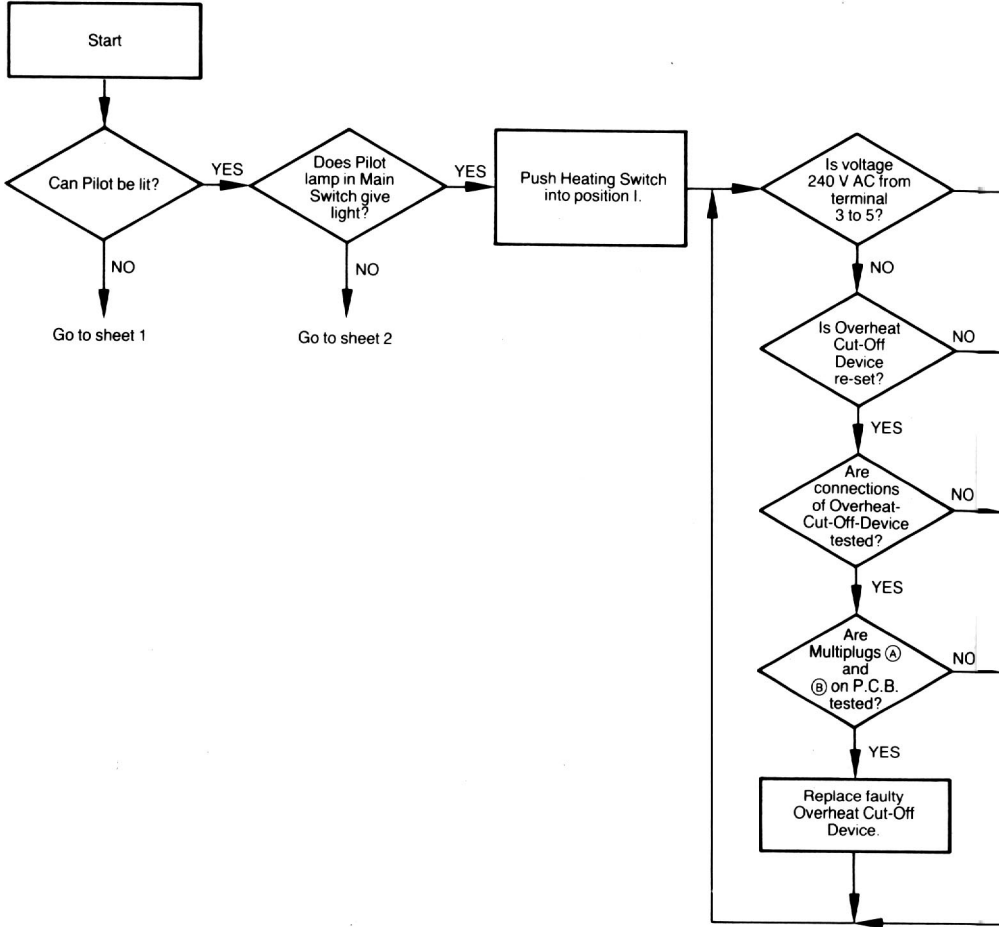

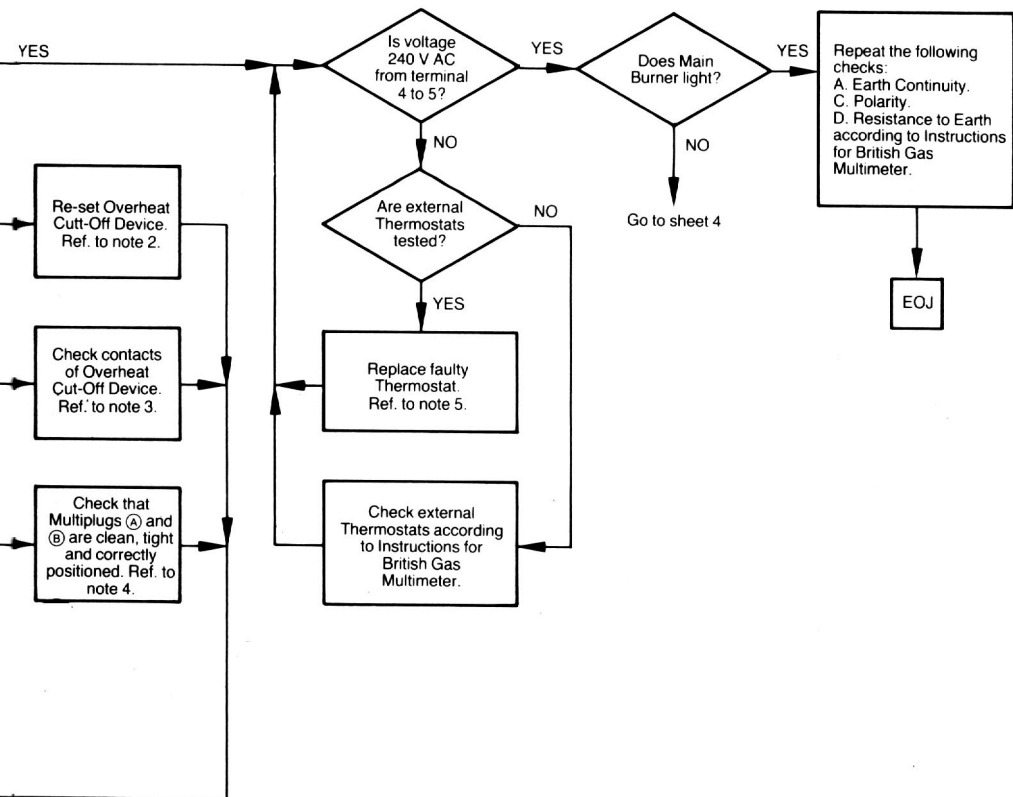

Note 2: For re-setting, press the black rubber button on right hand side of control box behind the terminal box.

Note 3: For this purpose, open the control box as described in Note 1. The overheat cut-off device is fitted on right hand side of the control box. Check if the flat plugs of the overheat cut-off device are tight.

Note 4: For this purpose, open the control box as described in Note 1. Pull off the multicontact plugs A and B and check that not contact lugs are bent. If necessary, readjust contact lugs and reset multicontact plugs again.

Note 5: To check, disconnect control system from terminals 3 and 4, and replace with wire loop to run boiler in heating mode.

9.4 Sheet 4: Check Electronic and Hydraulic System

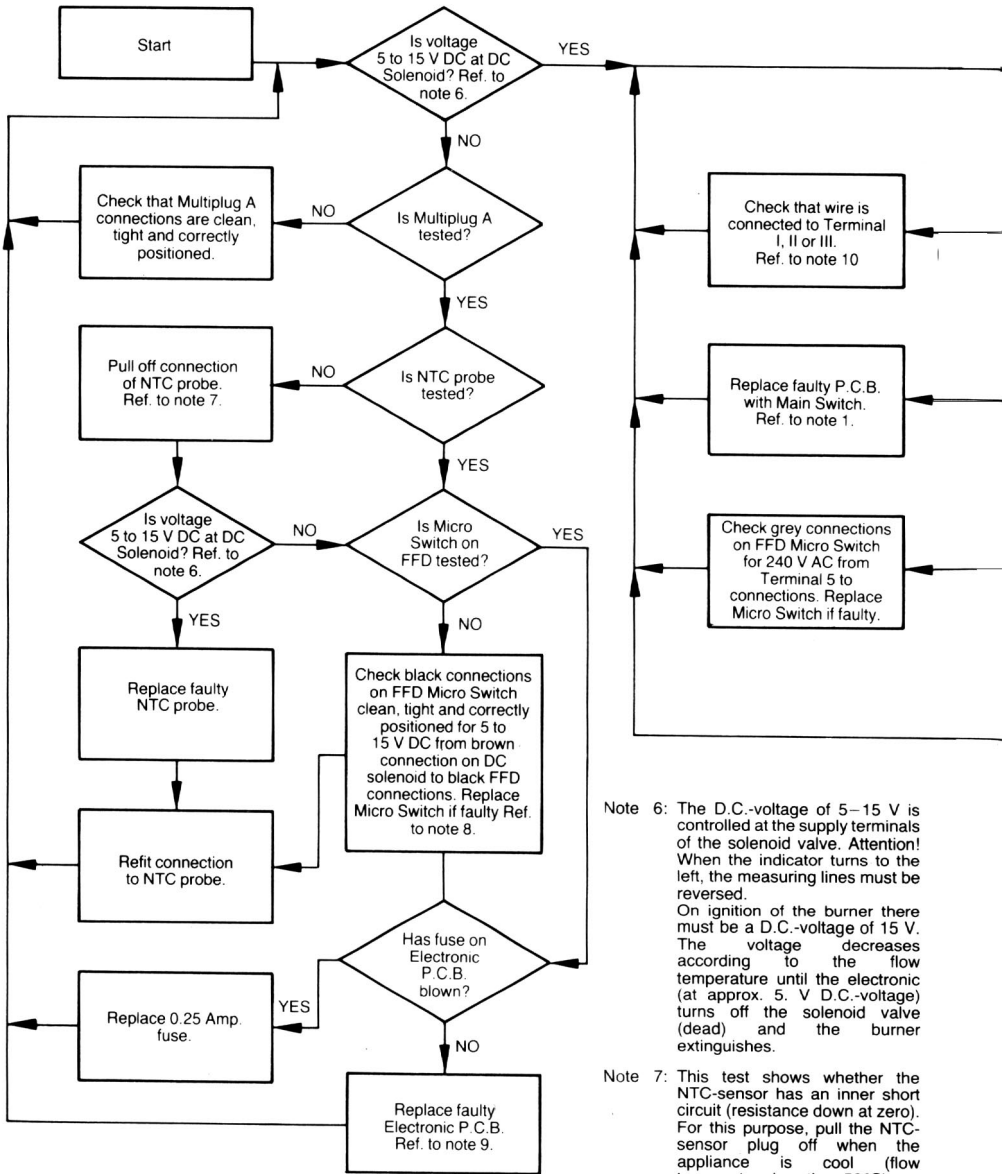

Note 6: The D.C.-voltage of 5–15 V is controlled at the supply terminals of the solenoid valve. Attention! When the indicator turns to the left, the measuring lines must be reversed. On ignition of the burner there must be a D.C.-voltage of 15 V. The voltage decreases according to the flow temperature until the electronic (at approx. 5 V D.C.-voltage) turns off the solenoid valve (dead) and the burner extinguishes.

Note 7: This test shows whether the NTC-sensor has an inner short circuit (resistance down at zero). For this purpose, pull the NTC-sensor plug off when the appliance is cool (flow temperature less than 50°C). If the electronic is satisfactory, the appliance must operate.

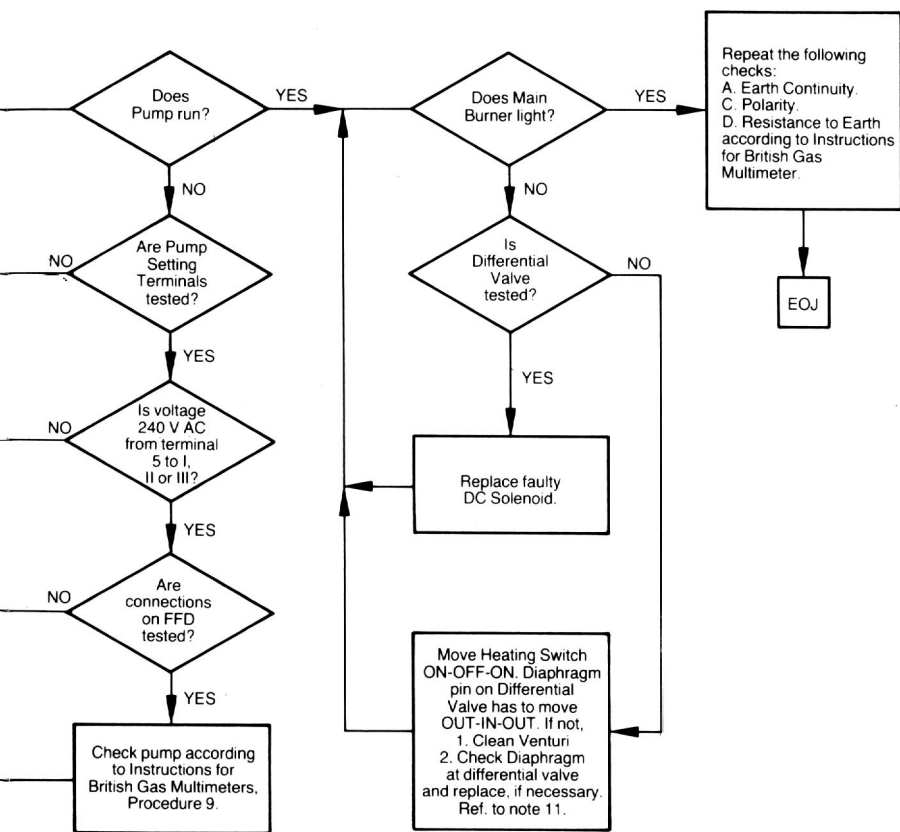

Attention! Pull off the NTC-plug for a short time only because the normal temperature control is out of function in that position. In this case the appliance is only protected by the overheat cut-off device.

Note 8: For this purpose, open the control box as described in Note 1. Unscrew the pilot gas tubes of the thermo-electric casing and check if the black cables of the micro switch are tight.

Afterwards install pilot gas tubes again.

Before re-assembling the control box, check the fine-wire fuse of the electronic. If necessary, replace it. Attach plugs A and B again and re-assemble control box.

Note 9: For this purpose, open control box as described in Note 1. Pull off the multicontact plugs A and B. The electronic-printed circuit can be removed by unscrewing the cross-recessed head screw on the left hand side of the control box. Pull out the printed circuit towards the front and pull off the multicontact plug as well as the white cable.

Install the electronic-printed circuit in reverse order.

Note 10: Attention: External lines must not be connected to the terminals I, II and III (short circuit!).

The black cable can be connected to terminal I, II or III. It must be checked whether the black cable is connected tightly enough.

Note 11: If the movement of the diaphragm pin cannot be checked optically, the pressure differential switch must be removed by unscrewing the 3 screws. Do not unscrew the two connection tubes!

Under perfect function the diaphragm pin cannot be pushed back by hand, when pump operates. If this is, however, possible, the venturi tube, pressure differential switch, connections tubes or pump, must be checked. Special attention must be given to the fact that the venturi O-ring is not damaged.

9.5 Sheet 5: Check Switch for Domestic Hot Water

(Heating Switch in position "O" do not use domestic hot Water)

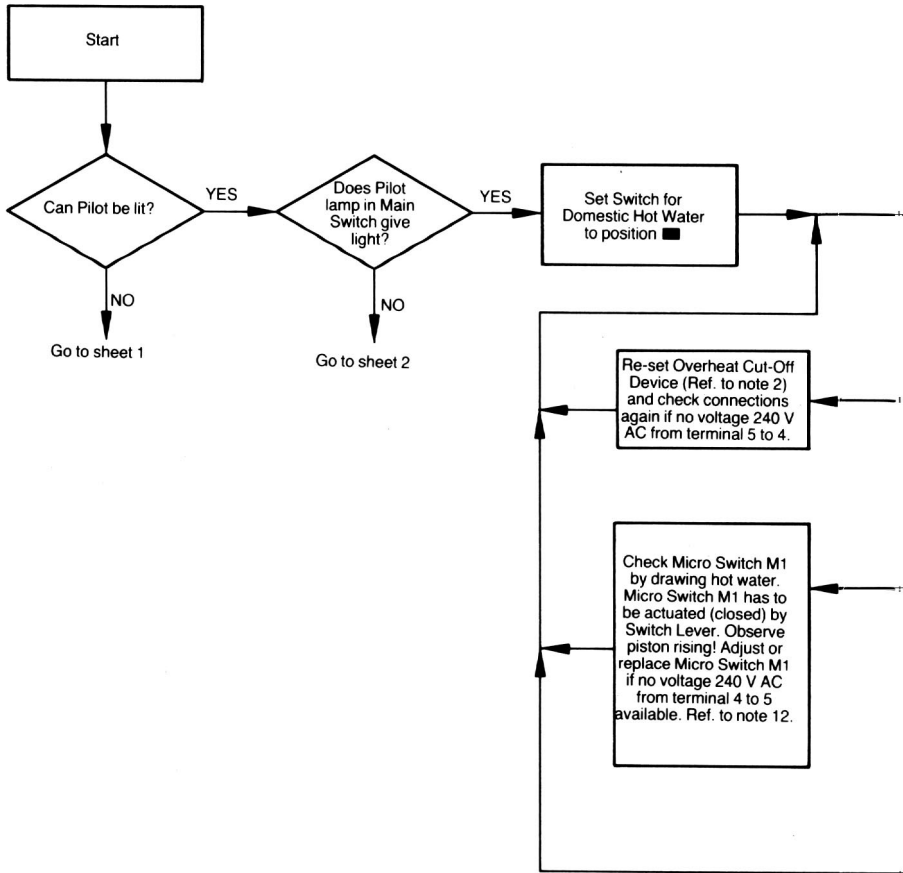

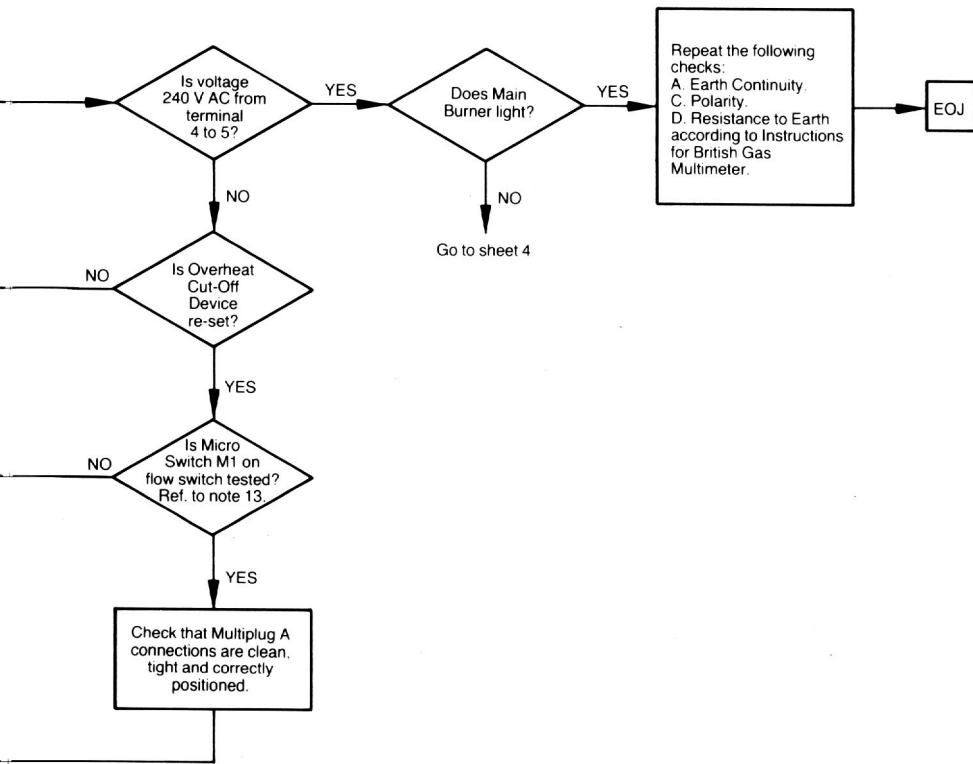

Note 12: The function "summer" is only controlled by the micro switch M1 of the flow switch. During domestic hot water function the contact lug must operate the micro switch M1 (close).

If the micro switch is not operated by the contact lug, an adjustment is necessary.

For this purpose, open the warm water tap (appliance out of operation – switch off main switch). Tighten the nut of the switch rod (top of flow switch) by means of a spanner, 7 mm, so that the contact lug operates the contact of the micro switch M1 (micro switch with two connection lines – 240 V.A.C.). In this case the contact lug must not touch the casing of the micro switch.

Note 13: See figure 99 for micro switch M1.

9.6 Sheet 6: Check Operation of Domestic Hot Water System

(Heating switch in position 0 switch for domestic hot water in position )

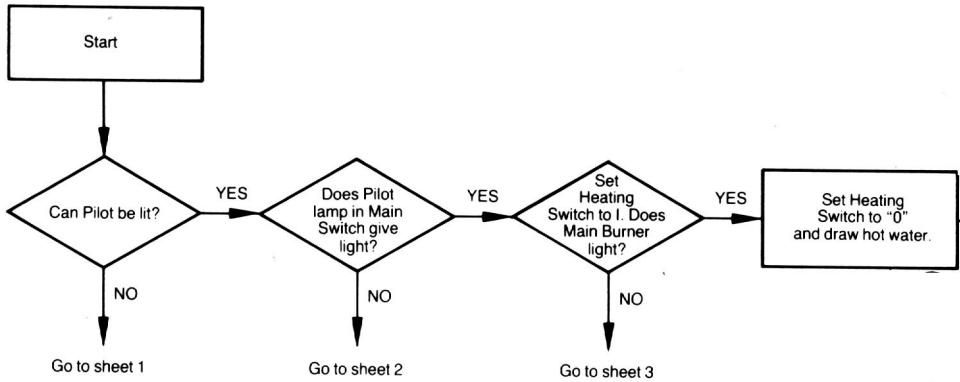

Note 14: For this purpose, open the control box as described in Note 1 and remove front panel.

Thus the micro switch is accessible and the movement of the switch pin of the water section can be observed. Open the warm water tap. With a water flow quantity of approx. 1 l/min. the switch pin must move and operate the micro switch via the switch lever which can be adjusted. If the switch pin of the water section does not move, the water section must be removed and checked (diaphragm).

If the micro switch does not operate despite the fact that the switch pin moves, the switch lever must be readjusted. For this, unscrew the support of the micro switch and push it downward until the switch lever contacts the top of water section. Fix the support in this position.

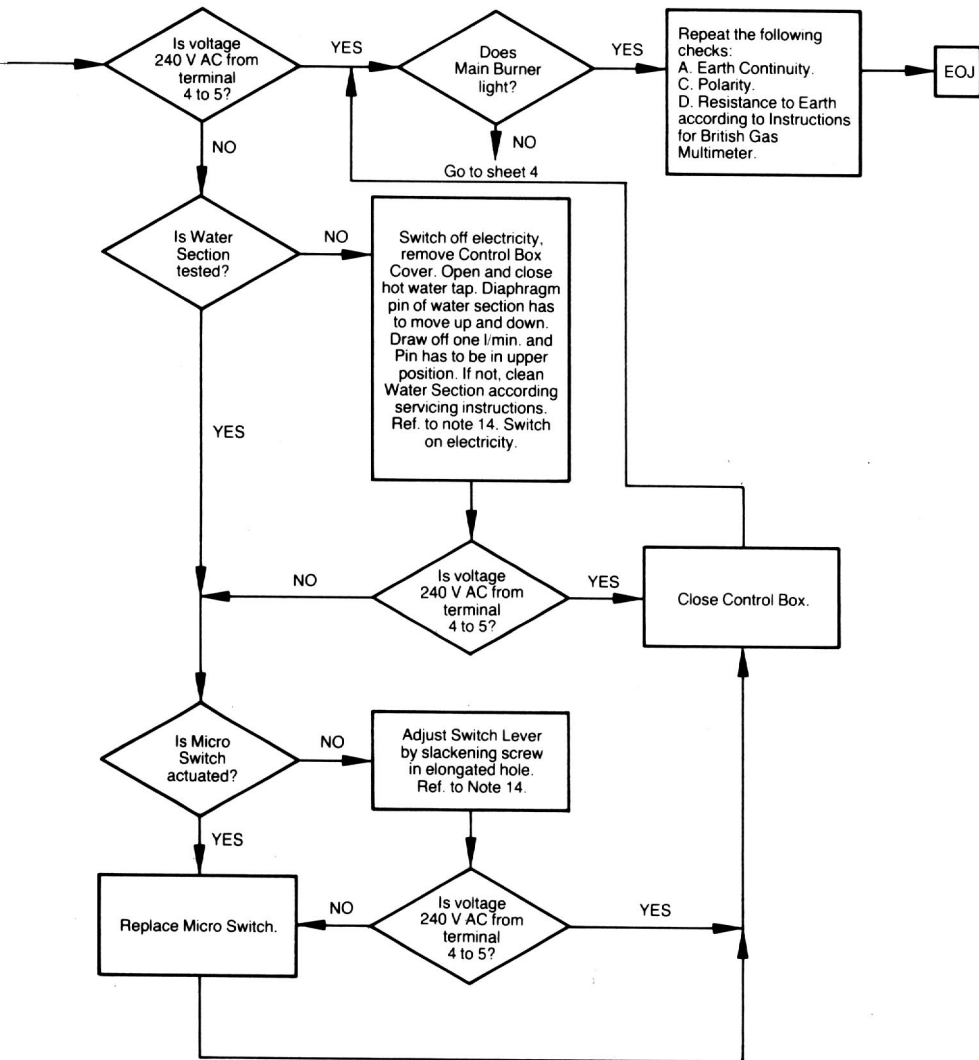

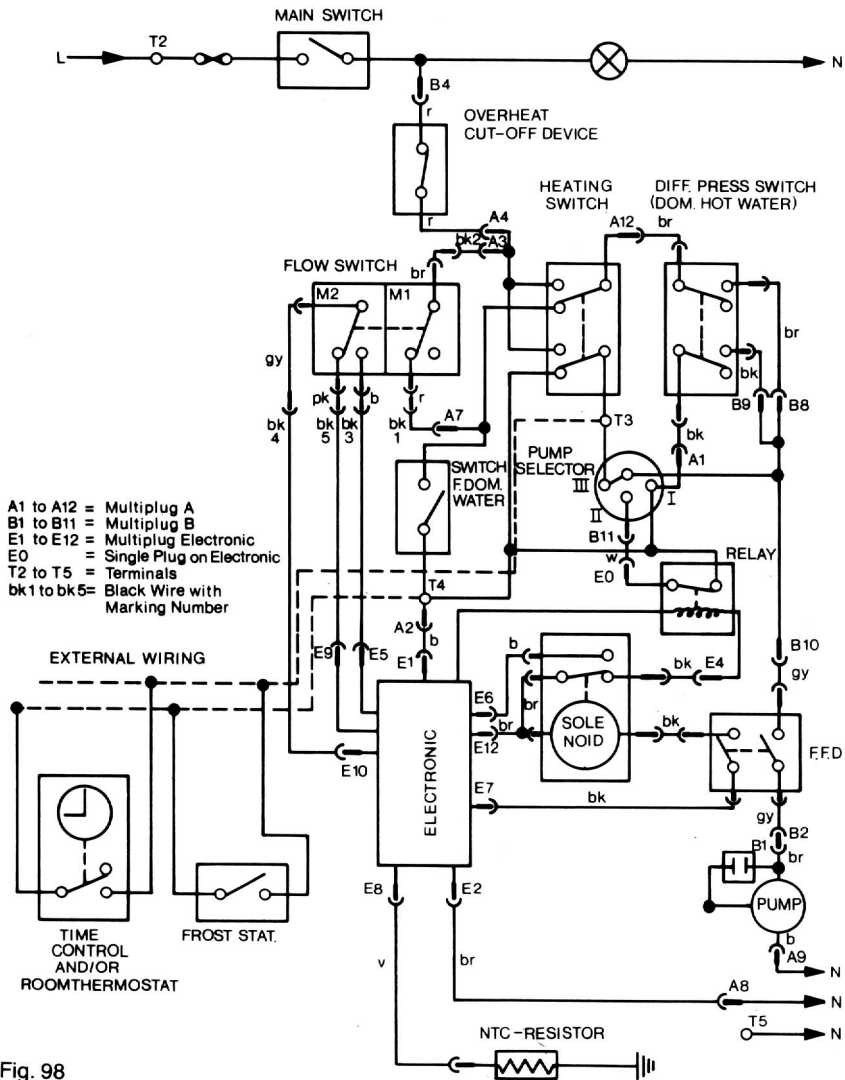

VC/VCW10/11

VCW-sine 18 T3W
VCW 20/1 T3W
VCW 25/1 T3W



47 044 01
47 044 03
47 044 05

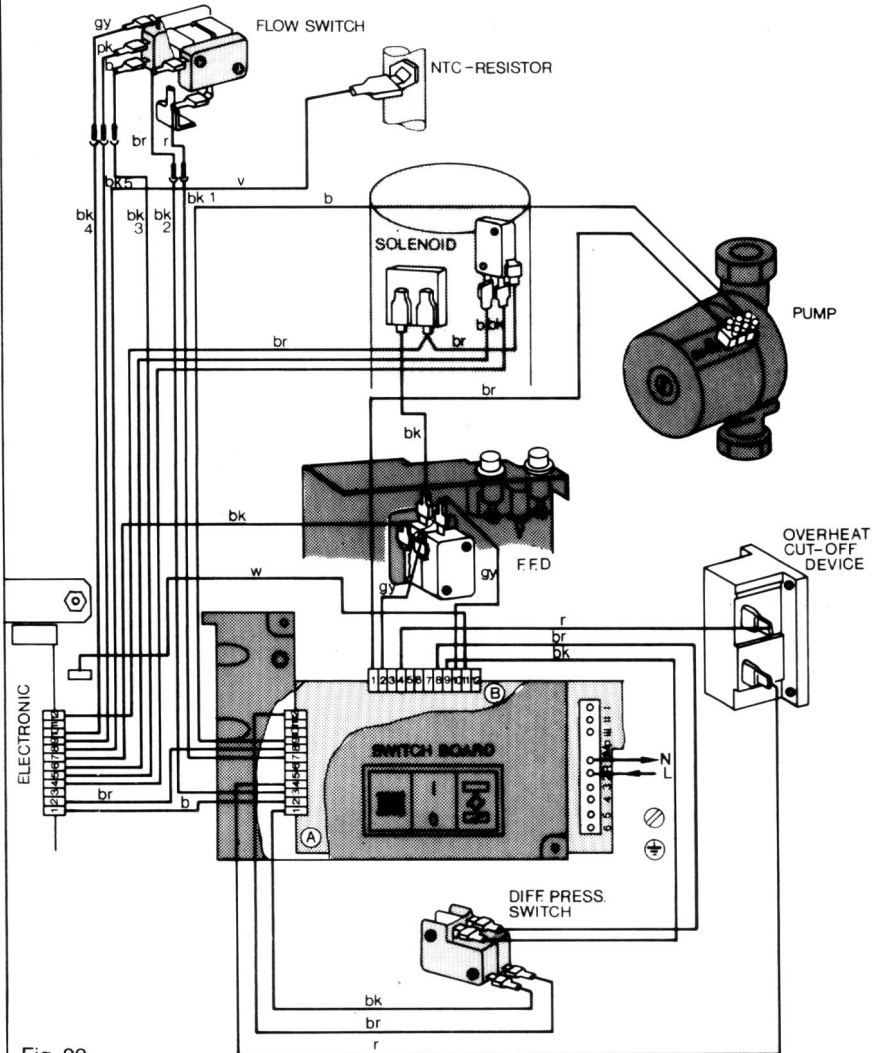
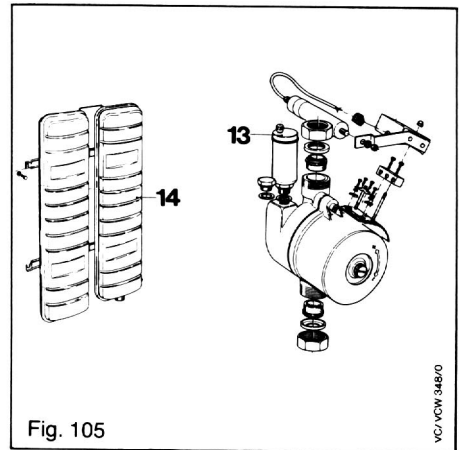
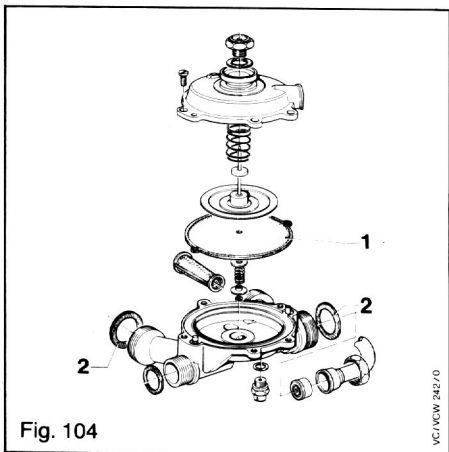
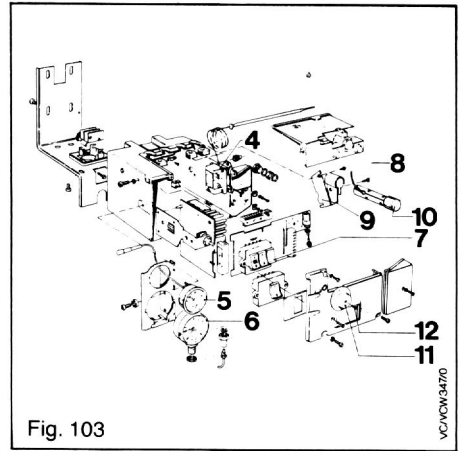
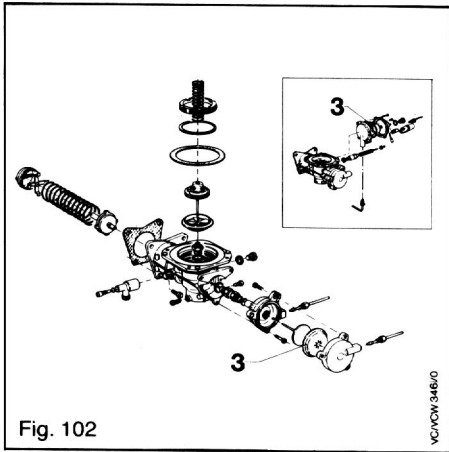
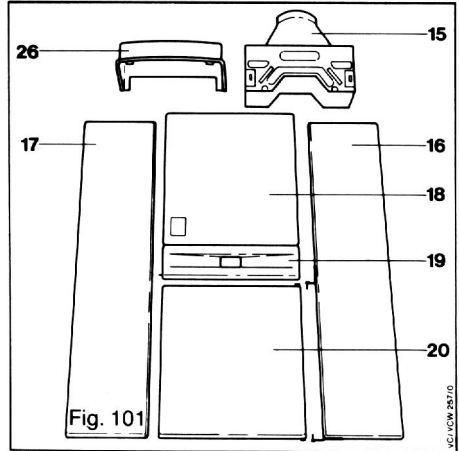
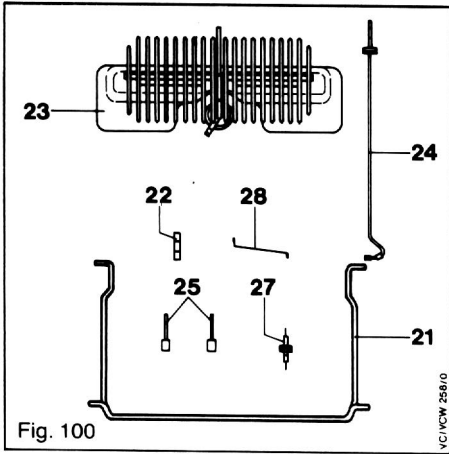

Fig. 99

VC/VCW 102/1



10 Short Part list

Key No.	Description	Part Number	G. C. Number
1	diaphragm	01-0318	262 329
2	washer	98-0151	262 335
3	diaphragm	02-0220	262 356
4	overheat cut-off device	10-1363	262 494
5	flow thermometer	10-1002	263 906
6	pressure gauge	10-1008	262 907
7	switch board	13-0132	262 489
8	screw	07-0334	—
9	support	08-6165	263 986
10	piëzo-unit	09-1008	263 987
11	knob	14-3935	262 488
12	screw	14-0012	—
13	automatic air vent	06-1704	263 935
14	expansion vessel	18-1001	263 950
15	draught diverter	VCW...20 07-3965	262 418
		VCW...25 07-3966	262 419
16	side panel righthand	VCW...20, VCW-sine 18 07-1143	262 446
		VCW...25 07-3730	262 427
17	side panel lefthand	VCW...20, VCW-sine 18 07-1144	262 425
		VCW...25 07-3729	262 426
18	front panel	VCW...20, 25 07-1043	262 437
		VCW-sine 18 07-4161	263 973
19	centre section	VCW...20, 25 07-1044	262 439
		VCW-sine 18 20-8619	263 974
20	door	VCW...20, 25 07-1046	262 433
		VCW-sine 18 07-4008	263 976
21	support	15-4205	262 416
22	protection cap	07-2306	262 398
23	burner complete	VCW...20 Natural Gas 04-4563	262 382
		VCW...25 Natural Gas 04-4564	262 383
24	thermocouple	17-1125	262 402
25	knob complete	green 11-4208	262 477
		red 11-4209	262 478
26	cover	07-2313	262 223
27	duct bolt complete	09-0102	262 216
28	high tension lead	08-4432	262 215

For your notes

For your notes

11 Technical Data

Type	VCW 20/1 T3 W	VCW 25/1 T3 W	VCW-sine 18 T3 W	
Nominal heating capacity	24 (81900) (86,4)	26,6 (90800) (95,8)	19,5 (66500) (70,2)	kW (BTU/h) (MJ/h)
Nominal heating input (based on gross C.V.)	31 (105800) (111,6)	35,5 (121200) (127,8)	26 (88700) (93,6)	kW (BTU/h) (MJ/h)
Pilot burner jet size for NG	34	34	40	marking
Main burner jet size for NG	14x7/130	16x7/130	12x1/125	number x mark.
Burner setting pressure	9,0 (3,61)	9,0 (3,61)	10,6 (4,26)	mbar (in WG)
Minimum water flow for heating system 20 °C rise	1000 (222)	1250 (278)	900 (200)	l/h (Imp. Gal./h)
Delivered gas Gross C.V. (s.t.p.) Gas consumption (s.r.c.)	G20 39,9 (1070) 2,95 (1,74)	G20 39,9 (1070) 3,38 (1,99)	G20 39,9 (1070) 2,47 (1,45)	MJ/m ³ (BTU/cu. ft) m ³ /h (c.f.m.)
Nominal capacity for domestic water	24 (1365)	26,6 (1513)	19,5 (1109)	kW (BTU/min)
Nominal capacity (water flow) of domestic water	7,6 (1,67)	8,5 (1,87)	6,2 (1,36)	l/min (45 K rise) (Imp. G./m. 81 °F rise)
Water capacity of heat exchanger	0,26 (0,057)	0,30 (0,066)	0,26 (0,057)	l (Imp. Gal.)
Nominal size of flue pipe		125 (5)	— —	mm (in.)
Max. nominal flow temperature		90 (194)		°C (°F)
Maximum total water- capacity of heating system (cold ¹⁾) for sealed system		260 (57,2)		l (Imp. Gal.)
Maximum water pressure Minimum static head for open heating system		10 (142) 0,15 (2,13)		bar (P.S.I.) bar (P.S.I.)
Minimum water pressure for domestic water supply of 1 l/min.		0,2 (2,84)		bar (P.S.I.)
Pump pressure available for central heating system appliance as delivered about UPS 18-60 spare head about		0,25 (8,4) 0,205 (6,9)		bar (feet) bar (feet)
Weight	59 (130)	60 (132)	68 (150)	kg (pound)
Electric connection	Voltage Input internal Fuse external Fuse	240/50 120 2 3		V/Hz W Amp (slow) Amp (slow)

¹⁾ For systems having a larger water capacity an additional expansion vessel can be installed easily. Subject to alteration.

Headquarters
Vaillant Ltd.
 Vaillant House
 Medway City Estate
 Trident Close
 Rochester/Kent
 ME 2 4 EZ
 Tel. 06 34-71 28 68 (Sales)
 Tel. 06 34-71 28 44 (Service)

Central Region Office
Vaillant Ltd.
 Unit 5
 Providence Industrial Estate
 Providence Street
 Lye, Stourbridge
 West Midlands DY 9 8 HQ
 Tel. 03 84-89 18 16 (Sales)
 Tel. 03 84-89 33 66 (Service)

Northern Region Office
Vaillant Ltd.
 Vaillant Building
 Euroway Estate
 Wharfedale Road
 Bradford
 West Yorkshire BD 4 6 SR
 Tel. 02 74-68 83 22
 (Sales/Service)

